

Fenaflex - Plus Series

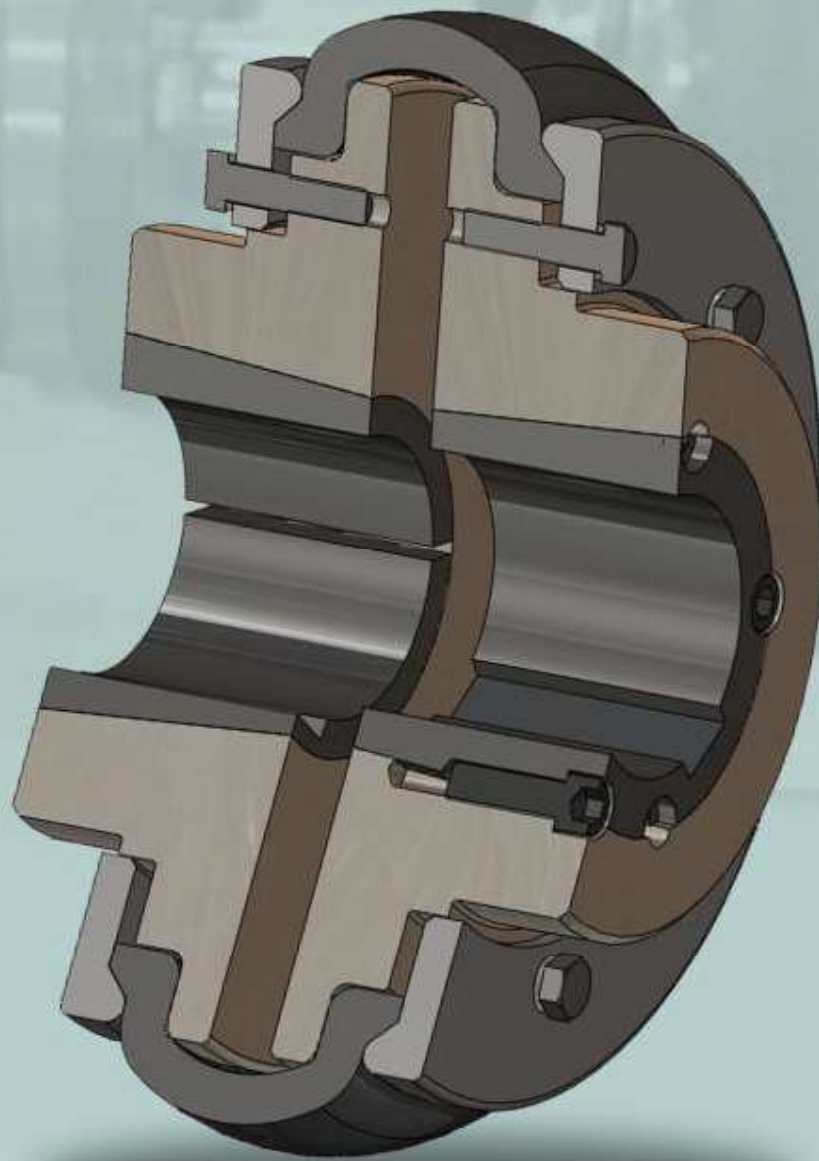

Tyre Couplings





Fenaflex® Plus Tyre couplings provide all the desirable features of an ideal flexible coupling, including Taper-Lock® fixing. The Fenaflex® Plus Tyre coupling is a "torsionally elastic" coupling offering versatility to designers and engineers with a choice of flange combinations to suit most applications.

The flanges are available in either F or H version Taper-Lock® fitting or bored to size B.

With the addition of a spacer flange, the coupling can be used to accommodate standard distance between shaft ends and facilitate pump maintenance.

Fenaflex® Plus Tyre couplings can accommodate simultaneous maximum misalignment in all planes without imposing undue loads on adjacent bearings and the excellent shock-absorbing properties of the flexible tyre reduce vibrations and torsional oscillations.

Fenaflex® Plus tyres are available in natural rubber compounds for use in ambient temperatures between -50°C to +50°C. Neoprene rubber compounds are available for use in adverse operating conditions e.g. oil or grease contaminations and can be used in temperatures of -15°C to +70°C.

F.R.A.S. tyres are available for use when fire-resistance and antistatic (F.R.A.S.) properties are required.

TORQUE-BORE RANGE

The range includes couplings with torque capacity upto 15020 Nm. and bore diameters upto 190 mm.

MISALIGNMENT

Handles parallel, angular and axial displacements, either singly or in any combination. They can accommodate parallel misalignment upto 6 mm, angular misalignment upto 4° and end float upto 8 mm.

TORSIONALLY SOFT

Cushions against destructive shock loads protecting the complete system, preventing expensive breakdowns and lengthens machine life.

FREE OF BACKLASH

Does not create 'snatch' on take up of the drive.

INSTALLATION

Requires neither special tools nor skilled labour to assemble. Alignment is quickly checked by placing a straight edge across outside diameter of flanges. The split flexible tyre is then positioned in the flanges and the screws tightened into place.

DAMPING

Reduces vibration and torsional oscillations developed in internal combustion engines, the amplitude of which increases greatly at critical points in the speed range. Fenaflex® Plus Tyre coupling dampens these destructive vibrations.

MAINTENANCE

Because there are no moving parts, no lubrication is required. Periodic visual inspection of the tyre is all that is necessary.

EASY ELEMENT REPLACEMENT

To replace flexible element simply loosen the clamping screws, remove the tyre and replace with a new one. It is not necessary to move either driver or driven machine or coupling flanges.

ENVIRONMENT

Use of natural or Neoprene rubber compounds makes the Tyre coupling suitable for use in most conditions. For fire hazard areas the F.R.A.S. tyre is recommended. This allows free flow of electricity between the two shafts to avoid static electricity buildup.

DETAILS REQUIRED FOR COUPLING SELECTION

1. Type of driven machine and operating hours per day.
2. Speed and power absorbed by driven machine (if absorbed power is not known, calculate on power rating of prime mover).
3. Diameters of shafts to be connected.

PROCEDURE

- a. **Service Factor**: Determine the required service factor from table-01.
- b. **Design Power** : Multiply the normal running power by the service factor. This gives the design power which is used as a basis for selecting the coupling.
- c. **Coupling Size**: Refer to table-03 (page-07) and from the appropriate speed, read across until a power greater than that required in step (b) is found.

The size of Fenaflex - Plus Tyre Coupling required is given at the head of that column.

- d. **Bore Size**: Check from dimension tables that chosen flanges can accommodate required bores.

EXAMPLE

A Fenaflex - Plus Tyre Coupling is required to transmit 45 kW from an A.C. Electric Motor which runs at 1440 rev/min to a rotary screen for 12 hours a day. The motor shaft is 42 mm diameter and the screen shaft is 48 mm diameter.

- a. **Service Factor**: From table -01 the service factor is 1.4.
- b. **Design Power**: Design Power = 45 x 1.4 = 63 kW.
- c. **Coupling Size**: By reading across from 1440 rev/min in table -03 (page-07) the first figure to exceed the required 63 kW in step (b) is 63.18 kW. The size of coupling is F80.
- d. **Bore Size**: By referring to table -02 (page-06) it can be seen that both shaft diameters fall within the bore range available.

TABLE -01: SERVICE FACTORS

Special Cases	Type of Driving Unit					
	Electric Motors Steam Turbines			Internal Combustion Engines Steam Engines Water Turbines		
	Operational hours per day					
Type of Driven Machine	10 and under	Over 10 to 16 inclusive	over 16	10 and under	Over 10 to 16 inclusive	over 16
CLASS 1 Agitators, Brewing machinery Centrifugal compressors and pumps, Belt conveyors, Dynamometers, Line shafts, Fans upto 7.5 kW, Blowers and Exhausters (except positive displacement) Generators.	0.8	0.9	1.0	1.3	1.4	1.5
CLASS 2 Clay working machinery, General Machine tools, Paper mill beaters and winders, Rotary pumps, Rubber extruders, Rotary screens, Textile machinery, Marine propellers and fans over 7.5 kW.	1.3	1.4	1.5	1.8	1.9	2.0
CLASS 3 Bucket elevators, Cooling tower fans, Piston compressors and pumps, Foundry machinery, Metal presses, Paper mill calendars, Pulverisers and Positive displacement blowers. Centrifugal compressors and pumps for Paper Mill.	1.8	1.9	2.0	2.3	2.4	2.5
CLASS 4 Reciprocating conveyors, Gyrotory crushers, Mills (ball, pebble and rod), Rubber machinery (Banbury mixers and mills) and Vibratory screens	2.3	2.4	2.5	2.8	2.9	3.0



F Type Couplings

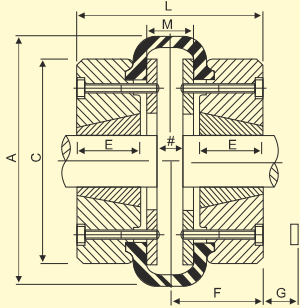

F - 40 & 45

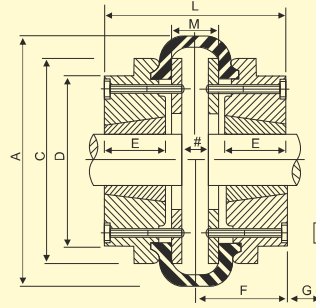

F - 50 & 60

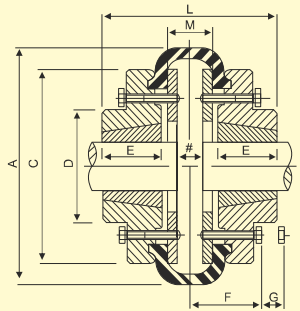

F - 70 TO 120

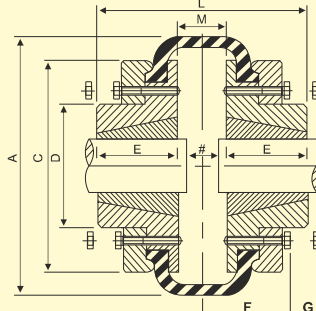

F - 140 TO 220

H Type Couplings

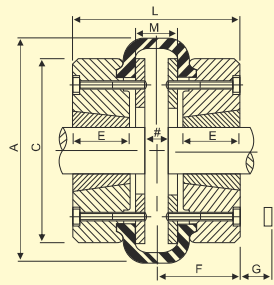

F - 40 & 45

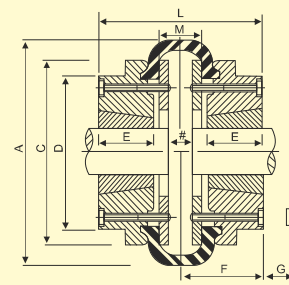

F - 50 & 60

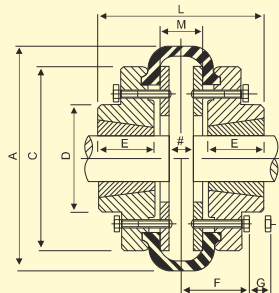

F - 70 TO 120

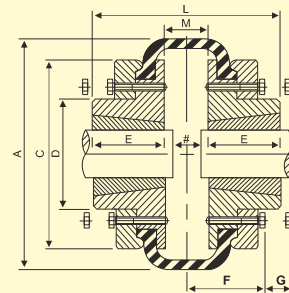

F - 140 TO 220

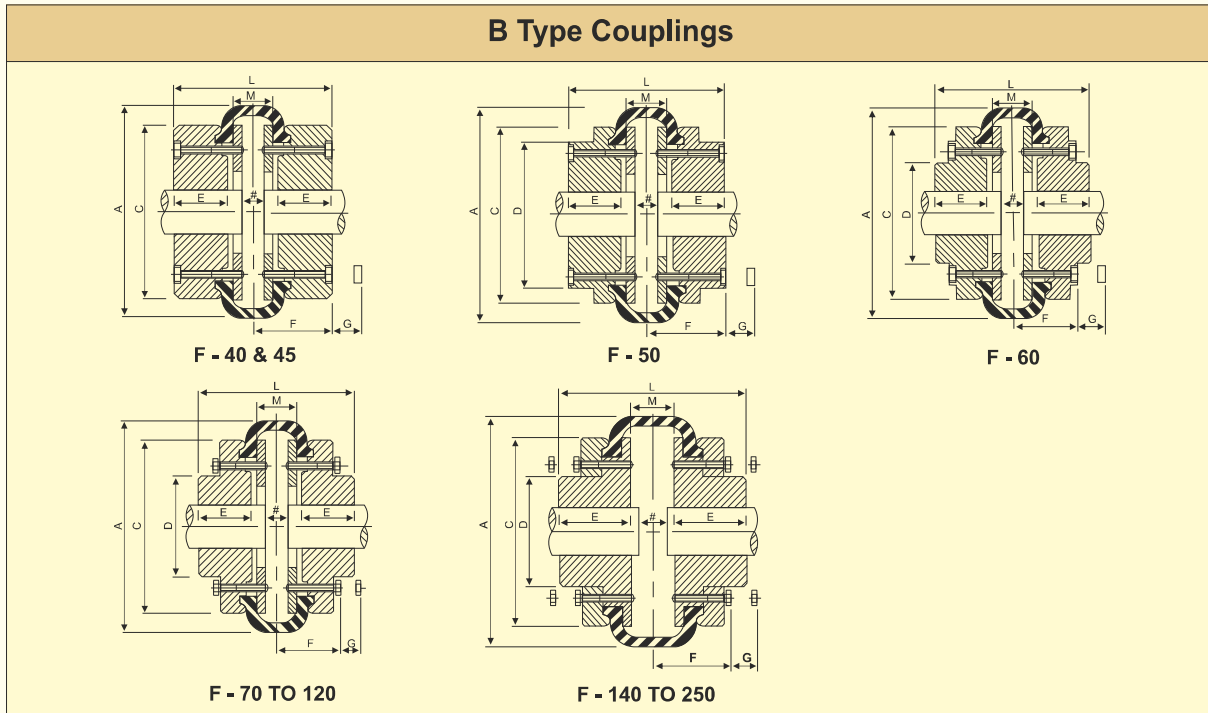

TABLE -02 : DIMENSIONS "F&H" AND "B" TYPE COUPLINGS

Size	TYPE F & H								TYPE B								A	C	G	M	No. of screws per flange
	Bush No.	Max Bore	L	D	E	F	J	Approx Weight Kg *	Max Bore	Min Bore	L	D	E	F	Set Screw on key	Approx Weight Kg *					
F40	1008	25	67	-	22	33.5	29	1.4	30	11.00	67	-	22	33.5	M5	2.0	104.0	82	43	23	4
F45	1108	28	67	-	22	33.5	29	3.0	32	11.00	73	-	25	36.5	M5	2.2	120.0	94	43	23	4
F50	1210	32	78	79.0	25	39.0	38	3.1	38	16.00	92	79	32	46.0	M5	4.0	133.5	100	43	28	4
F60	1610	42	86	103.0	25	43.0	38	5.2	48	16.00	112	83	38	43.0	M6	5.0	165.0	125	43	36	5
F70	1610	42	92	76.0	25	50.5	38	7.4	55	19.05	132	82	45	50.5	M6	8.0	197.0	144	10	42	5
F80	2012	50	111	95.0	32	53.0	47	9.2	65	25.40	149	95	51	53.0	M10	12.0	211.0	167	10	47	6
F85	2012	50	112	103.0	32	53.5	47	12.5	70	31.75	154	103	53	53.5	M12	14.0	222.0	179	13	48	6
F90	2517	60	140	110.0	45	59.5	50	15.0	76	31.75	164	110	57	59.5	M12	15.0	235.0	188	13	50	6
F100	2517	60	148	124.0	45	61.5	50	20.0	85	31.75	178	124	60	61.5	M12	21.0	254.0	216	13	58	6
F110	2517	60	140	134.0	45	63.5	50	26.5	90	31.75	180	134	65	63.5	M12	28.0	279.0	233	14	50	6
F120	3020	75	157	152.0	51	70.0	68	35.5	102	38.10	207	152	76	70.0	M12	41.0	314.0	264	14	55	6
F140	3535	90	204	194.5	89	76.0	89	67.2	120	75.00	204	195	89	76.0	M20	61.0	359.0	313	14	26	8
F160	4040	100	220	216.0	102	78.0	110	91.0	140	75.00	220	216	102	78.0	M20	86.0	402.0	345	19	16	8
F180	4545	110	258	266.0	114	94.0	126	146.0	150	75.00	258	266	114	94.0	M20	141.0	470.0	398	19	30	10
F200	4545	110	278	266.0	114	103.0	126	182.0	150	75.00	276	266	114	103.0	M20	179.0	508.0	429	19	48	12
F220	5050	127	312	267.0	127	118.0	140	320.0	160	90.00	312	267	127	118.0	M20	312.0	562.0	474	20	56	12
F250	-	-	-	-	-	-	-	-	190	100.00	360	290	150	125.0	M20	500.0	628.0	532	25	60	12

* Weights given are for min. bore complete coupling.

† M is the distance between flanges.

Shaft ends, although normally located 'M' apart - can project beyond the flanges as shown. In this event, allow sufficient space between shaft ends for the float and misalignment.

‡ G is the amount by which clamping screws need to be withdrawn to release tyre.

§ J is the wrench clearance to allow for tightening and loosening the bush on the shaft. The use of shortened wrench will allow this dimension to be reduced.

Dimensions are in millimetres

Power Ratings

TABLE -03 : POWER RATINGS (kW)

Speed (rev/min)	COUPLING SIZE																
	F40	F45	F50	F60	F70	F80	F85	F90	F100	F110	F120	F140	F160	F180	F200	F220	F250
100	0.54	0.85	1.15	2.30	2.64	4.39	5.18	5.36	6.38	9.21	14.14	28.80	40.84	66.54	97.91	127.96	157.28
200	1.09	1.70	2.30	4.61	5.28	8.77	10.37	10.72	12.75	18.43	28.27	57.59	81.68	133.09	195.81	255.92	314.55
300	1.63	2.54	3.46	6.91	7.92	13.16	15.55	16.08	19.13	27.64	42.41	86.39	122.51	199.63	293.72	383.87	471.83
400	2.18	3.39	4.61	9.21	10.55	17.55	20.73	21.45	25.51	36.86	56.54	115.18	163.35	266.18	391.62	511.83	629.11
500	2.72	4.24	5.76	11.52	13.19	21.94	25.92	26.81	31.88	46.07	70.68	143.98	204.19	332.72	489.53	639.79	786.39
600	3.27	5.09	6.91	13.82	15.83	26.32	31.10	32.17	38.26	55.29	84.82	172.77	245.03	399.27	587.43	767.75	943.66
700	3.81	5.94	8.06	16.13	18.47	30.71	36.28	37.53	44.64	64.50	98.95	201.57	285.86	465.81	685.34	895.71	1100.94
720	3.92	6.11	8.29	16.59	19.00	31.59	37.32	38.60	45.91	66.35	101.78	207.33	294.03	479.12	704.92	921.30	1132.40
800	4.36	6.79	9.21	18.43	21.11	35.10	41.47	42.89	51.02	73.72	113.09	230.37	326.70	532.36	783.25	1023.66	1258.22
900	4.90	7.63	10.37	20.73	23.75	39.49	46.65	48.25	57.39	82.93	127.23	259.16	367.54	598.90	881.15	1151.62	1415.50
960	5.23	8.14	11.06	22.12	25.33	42.12	49.76	51.47	61.22	88.46	135.71	276.44	392.04	638.83	939.90	1228.40	1509.86
1000	5.45	8.48	11.52	23.04	26.39	43.87	51.83	53.61	63.77	92.15	141.36	287.96	408.38	665.45	979.06	1279.58	1572.77
1200	6.53	10.18	13.82	27.64	31.66	52.65	62.20	64.34	76.52	110.58	169.63	345.55	490.05	798.53	1174.87		
1400	7.62	11.87	16.13	32.25	36.94	61.42	72.57	75.06	89.28	129.01	197.91	403.14	571.73	931.62			
1440	7.84	12.21	16.59	33.17	38.00	63.18	74.64	77.20	91.83	132.69	203.56	414.66	588.06	958.24			
1600	8.71	13.57	18.43	36.86	42.22	70.20	82.93	85.78	102.03	147.43	226.18	460.73	653.40				
1800	9.80	15.27	20.73	41.47	47.50	78.97	93.30	96.50	114.79	165.86	254.45	518.32					
2000	10.89	16.96	23.04	46.07	52.77	87.75	103.66	107.23	127.54	184.29	282.72						
2200	11.98	18.66	25.34	50.68	58.05	96.52	114.03	117.95	140.29	202.72							
2400	13.07	20.36	27.64	55.29	63.33	105.30	124.40	128.67	153.05								
2600	14.16	22.05	29.95	59.90	68.61	114.07	134.76	139.39	165.80								
2800	15.25	23.75	32.25	64.50	73.88	122.85	145.13	150.12									
2880	15.68	24.43	33.17	66.35	76.00	126.36	149.28	154.40									
3000	16.34	25.45	34.55	69.11	79.16	131.62	155.50										
3500	19.06	29.69	40.31	80.63	92.36												
3600	19.60	30.53	41.47	82.93													

The figures in heavier type are for standard motor speeds

For speeds below 100 rev/min and intermediate speeds, use normal torque ratings.

Physical Characteristics

TABLE -04 : PHYSICAL CHARACTERISTICS

Size	Max. Speed (rev/min)	Torque (Nm)		Moment of inertia MR ² (kgm ²)	Torsional Stiffness (Nm/°)	Maximum Misalignment (mm)	
		Nominal	Max.			Parallel	End float ±
F40	4500	52	156	0.00148	5	1.1	1.3
F45	4500	81	243	0.00250	9	1.2	1.5
F50	4500	110	330	0.00349	13	1.3	1.7
F60	4000	220	660	0.01030	26	1.6	2.0
F70	3600	252	756	0.01811	41	1.9	2.3
F80	3100	419	1257	0.03679	63	2.1	2.6
F85	3000	495	1485	0.05015	76	2.2	2.8
F90	2880	512	1536	0.06374	91	2.4	3.0
F100	2600	609	1827	0.11989	126	2.6	3.3
F110	2300	880	2640	0.16012	178	2.9	3.7
F120	2050	1350	4050	0.34302	296	3.2	4.0
F140	1800	2750	8250	0.69452	470	3.7	4.6
F160	1600	3900	11700	1.21767	778	4.2	5.3
F180	1500	6355	19065	2.01800	1371	4.8	6.0
F200	1300	9350	28050	4.03446	1959	5.3	6.6
F220	1100	12220	36660	8.67644	2760	5.8	7.3
F250	1000	15020	45060	16.85095	3562	6.6	8.2

Notes:

1. Maximum torque figures should be regarded as short duration overload ratings for use in such circumstances as direct-on-line starting etc.
2. All flexible tyres have an angular misalignment capacity upto 4°

TABLE -05

Coupling Size		F40*	F45*	F50*	F60*	F70	F80	F85	F90	F100	F110	F120	F140	F160	F180	F200	F220	F250
M2 (mm)		23	23	28	36	42	47	48	50	58	50	55	26	16	30	48	56	60
Clamping Screw Torque	Nm	15	15	15	35	35	35	40	55	55	60	70	70	80	100	120	165	165
	Clamping Bolt size	M6	M6	M6	M8	M8	M8	M10	M10	M10	M10	M10	M12	M12	M16	M16	M16	M20

* Hexagonal Socket Cap Head Clamping Screws on these sizes.

INSTALLATION

Installation Instructions

Note : Satisfactory performance depends on correct installation and maintenance. All instructions in this manual must therefore be followed carefully.

1. Thoroughly clean all components, paying particular attention to the removal of the protective coating in the bore of the flanges.
2. Fit flanges to the shafts placing the external clamp rings on the shafts. (Where Taper-Lock® flanges are used, see separate fitting instructions supplied with the Taper-Lock® Bushes). Locate flanges so that dimension M2 is obtained (see paragraph 3). Flanges with internal clamping rings should then have the clamping rings fitted, engaging only two or three of the threads of the screws at this time.
3. Bring shafts into line until dimension M2 is obtained (table-05). If shaft end float is to occur, locate the shafts at mid-position of end float when checking dimension M2. Note that shaft ends may project beyond the faces of the flanges if required. In this event, allow sufficient space between shaft ends for end float and misalignment. Flanges should be fitted flush with the end of the shaft when used with Mill-Motor flanges.

4. Check parallel alignment by laying a straight edge across the flanges at several positions around the circumference. Check angular alignment by measuring gap between flanges at several positions around the circumference. It is desirable to align the coupling as accurately as possible, particularly on high speed applications.
5. Open out tyre and fit over coupling flanges ensuring that the tyre beads seat properly on the flanges and/or clamping rings. To ensure proper seating, it may be necessary to strike the outside diameter of the tyre with a small mallet. When seated, there should be a gap between the ends of the tyre as shown in table 6.

TABLE-06

COUPLING SIZE	F40 TO F60	F70 TO F120	F140	F160 TO F180	F200 TO F250
Tyre Gap in mm.	2	3	5	6.5	8

6. Tighten clamping ring screws alternately and evenly (half turn at a time) working round each flange until the required screw torque is achieved.

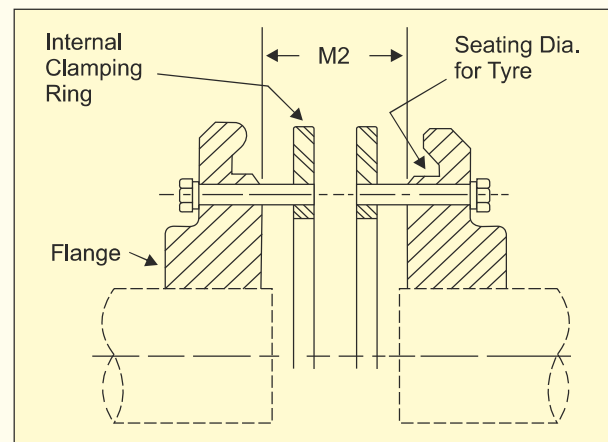
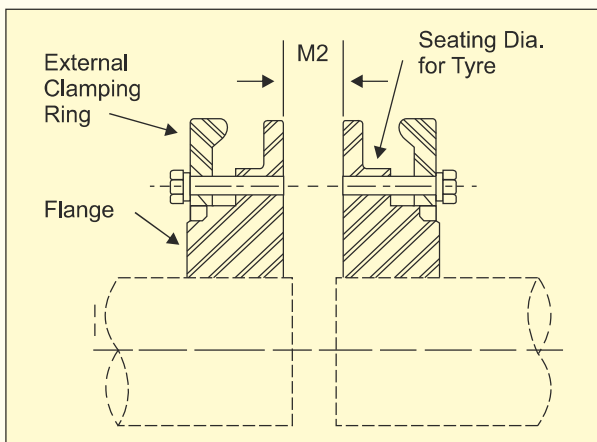

Fenaflex-Plus Tyre Spacer Couplings

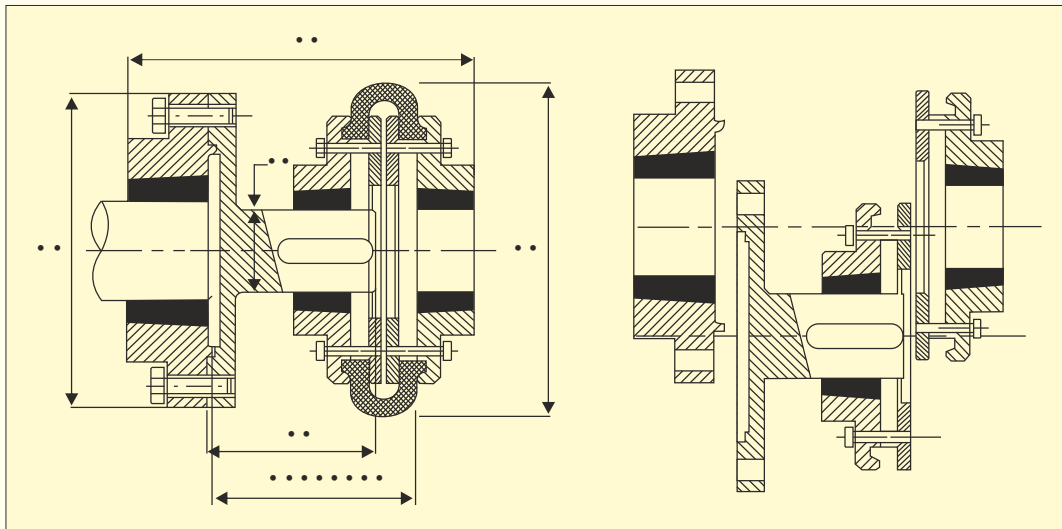

Comprising a Tyre coupling (size F40-F140) complete with a spacer flange designed for use on applications where it is an advantage to be able to move either shaft axially without disturbing the driving or driven machine; e.g. centrifugal pump rotors. Fenaflex-Plus Type spacer couplings are primarily designed for the standard distance between shaft end dimensions 100, 140 and 180 mm.

TABLE -07

SPACER SIZE	DBSE	FENAFLEX - PLUS TYRE COUPLING SIZE	SPACER BUSH SIZE	MAX. BORE	FENAFLEX - PLUS TYRE COUPLING BUSH SIZE	MAX. BORE	A	C	E	S	T
SM12	80	F40	1210	32	1008	25	104	118	134	77	25
SM12	100	F40	1210	32	1008	25	104	118	140	97	25
SM16	100	F40 *	1615	42	1008	25	104	127	170	94	32
SM16	140	F40 *	1615	42	1008	25	104	127	210	134	32
SM16	100	F50	1615	42	1210	32	133.5	127	173	94	32
SM16	140	F50	1615	42	1210	32	133.5	127	213	134	32
SM16	100	F60	1615	42	1610	42	165	127	177	94	32
SM16	140	F60	1615	42	1610	42	165	127	214	134	32
SM25	100	F70	2517	60	1610	42	197	178	180	94	42
SM25	140	F70	2517	60	1610	42	197	178	220	134	42
SM25	180	F70	2517	60	1610	42	197	178	260	174	42
SM25	100	F80	2517	60	2012	50	211	178	193	94	48
SM25	140	F80	2517	60	2012	50	211	178	233	134	48
SM25	180	F80	2517	60	2012	50	211	178	273	174	48
SM25	140	F90	2517	60	2517	60	235	178	235	134	48
SM25	180	F90	2517	60	2517	60	235	178	275	174	48
SM30	140	F100	3030	75	2517	60	254	216	269.5	134	60
SM30	180	F100	3030	75	2517	60	254	216	309.5	174	60
SM30	140	F110	3030	75	2517	60	279	216	369.5	134	60
SM30	180	F110	3030	75	2517	60	279	216	309.5	174	60
SM35	140	F120	3535	90	3020	75	314	248	297.5	134	75
SM35	180	F120	3535	90	3020	75	314	248	327.5	174	75
SM35	140	F140	3535	90	3535	90	359	248	296	134	80
SM35	180	F140	3535	90	3535	90	359	248	336	174	80

* F40 'B' Flange must be used to fit spacer shaft.



PRODUCT RANGE



V Cool Pulley



Vibrator Motor



SMSR Plus Series



Tough nut Gear Boxes



Parallel Helical Geared Motor



Aerators