

Essex Jaw Couplings



Fenner

POWERTRAN

SALIENT FEATURES

- Simple construction - quick easy installation - No special tools required.
- Flexible insert caters for incidental angular, parallel and axial misalignment.
- Absorbs shock loads and damps small amplitude vibration.
- Insert design presets correct distance between hubs, using raised pads on each leg of the insert.
- Available in a range of stock bore sizes. Can also be supplied with finished bore & keyway.
- Unaffected by moisture, grease and oils-including non-aromatic and non-ketone solvents and temperatures within the range - 40°C to + 100°C.
- Spacer coupling with spacer size depending upon the distance between two shaft ends (DBSE).

SELECTION

Details required for couplings selection

1. Type of driven machine and operating hours per day.

2. Speed and power absorbed by driven machine (if absorbed power is not known, calculate on power rating of prime mover).
3. Diameter of shafts to be connected.
4. Distance between two shaft ends in case of spacer coupling.

PROCEDURE

a) Service Factor

Determine the required service factor from table.

b) Design Power

Multiply the normal running power by the service factor. This gives the Design Power which is used as a basis for selecting the coupling.

c) Coupling Size

Depending upon the type of coupling required, refer to respective power rating tables. Power ratings can be interpolated in relation to speed parameters.

d) Bore Size

Check from the dimension table to see if bore capacity of the couplings is adequate. Otherwise select next higher size coupling.

SERVICE FACTORS

Type of Driven Machine	Type of Driving Unit		
	Electric Motors & Steam Turbines	Internal Combustion Engines	
		More than six cylinders	Less than six cylinders
Uniform Load Agitators, Brewing machinery, Centrifugal compressors and pumps, Belt conveyors, Dynamometers, Lineshafts, Fans upto 7.5 kW, Blowers and exhausters except positive displacement, Generators.	1.0	1.5	2.0
Moderate Shock Clay working machinery, General machine tools, Paper mill beaters and winders, Rotary pumps, Rubber extruders, Rotary screens, Textile machinery, Marine propellers and fans over 7.5 kW.	1.5	2.0	2.5
Heavy Shock Bucket elevators, Cooling tower fans, Piston compressors and pumps, Foundry machinery, Metal presses, Paper mill calenders, Hammer mills, Presses and pulp grinders, Rubber calenders, Pulverisers and positive displacement blowers.	2.0	2.5	3.0

Essex Jaw Couplings



STANDARD COUPLINGS

Size	Power per 100 rev/min kW	Bore in mm		Dimensions in mm				
		Min.	Max.	A	B	D	F	G
F - 095	0.21	15	28	63	54	49	2	25
F - 099	0.39	20	30	72	65	51	2	27
F - 0100	0.50	20	38	88	65	57	2	35
F - 0110	0.92	20	42	108	85	76	3	43
F - 0150	1.50	30	48	115	96	80	3	45
F - 0190	2.02	36	55	133	115	102	3	54
F - 0225	2.75	40	60	153	127	108	3	64

STANDARD SPACER COUPLINGS

Size	Power per 100 rev/min kW	Bore in mm		Distance between shaft ends (DBSE) A	Dimensions in mm		
		Min.	Max.		B	C	X
F-095 S	0.21	15	28	90/100	54	25	6
F-0100 S	0.50	20	38	90/100/140	65	30	6
F-0110 S	0.92	20	42	90/100/140	85	35	8
F-0150 S	1.50	30	48	90/100/140	96	45	10
F-0190 S	2.02	36	55	90/100/140	115	51	10
F-0225 S	2.75	40	60	90/100/140	127	57	12

EXTERNAL SPIDER COUPLINGS

Size	Power per 100 rev/min kW	Bore in mm		Dimensions in mm				
		Min.	Max.	A	B	D	F	G
F - 095 E	0.23	15	23	63	64	49	2	25
F - 099 E	0.38	20	30	72	77	51	2	27
F - 0100 E	0.50	20	38	88	77	57	2	35
F - 0110 E	0.91	20	42	108	95	76	3	43
F - 0150 E	1.47	30	48	115	110	80	3	45
F - 0190 E	2.03	36	55	135	128	102	3	54
F - 0225 E	2.80	40	60	153	141	108	3	64

EXTERNAL SPIDER ALUMINIUM SPACER COUPLINGS

Size	Power per 100 rev/min kW	Bore in mm		Distance between shaft ends (DBSE) A	Dimensions in mm			
		Min.	Max.		B	C	D	F
F-095 ES	0.23	15	28	90/100/140	64	25	49	2
F-0100 ES	0.50	20	38	90/100/140	77	35	57	2
F-0110 ES	0.91	20	42	90/100/140	95	43	76	3
F-0150 ES	1.47	30	48	90/100/140	110	45	80	3
F-0190 ES	2.03	36	55	90/100/140	128	54	102	3
F-0225 ES	2.80	40	60	90/100/140	141	64	108	3

CUSHION COUPLINGS

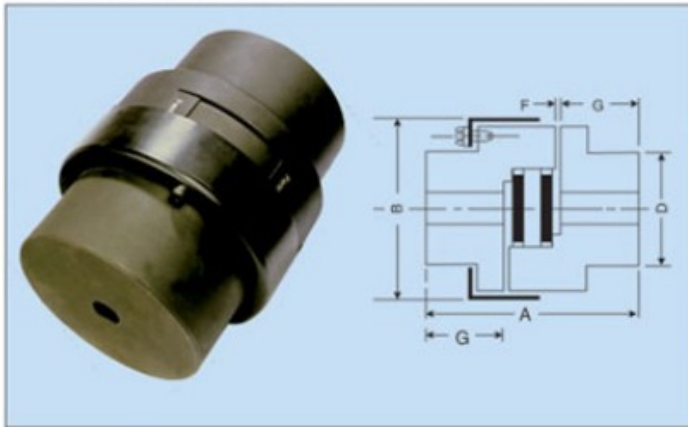

Size	Power per 100 rev/min kW	Bore in mm		Dimensions in mm				
		Min.	Max.	A	B	D	F	G
F-0226 P	3.45	25	65	178	143	115	3	70
F-0276 P	5.60	25	75	200	163	127	3	80
F-0280 P	8.20	30	75	200	200	140	3	80
F-0295 P	13.40	40	90	238	245	160	3	95
F-02955 P	22.40	50	100	264	245	180	3	108

CUSHION SPACER COUPLINGS

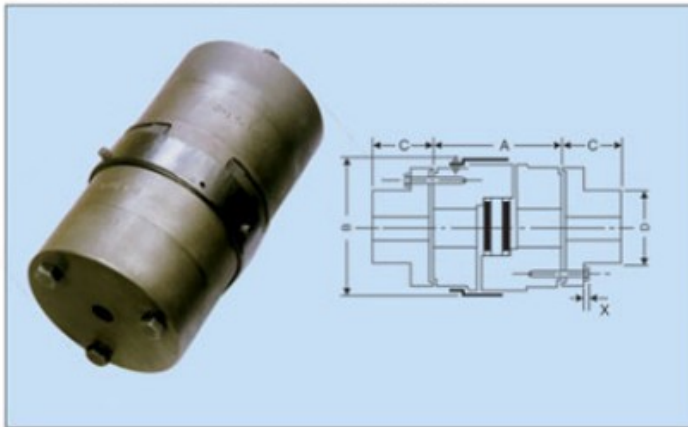

Size	Power per 100 rev/min kW	Bore in mm		Distance between shaft ends (DBSE) A	Dimensions in mm			
		Min.	Max.		B	C	D	X
F-0226 PS	3.45	25	65	135/140/180	145	50	134	12
F-0276 PS	5.60	25	75	135/140/180	165	60	130	12
F-0280 PS	8.20	30	75	135/140/180	200	60	130	14
F-0295 PS	13.40	40	90	135/140/180	249	65	160	16
F-02955 PS	22.40	50	90	135/140/180	249	80	160	16



TYPICAL APPLICATIONS

Pumps including back-pull-out type, Conveyors, Elevators, Packaging Machinery, Food Processing Plants, Compressors, General Machine Tools, Blowers, Paper Mill Beaters and Calenders, etc.