

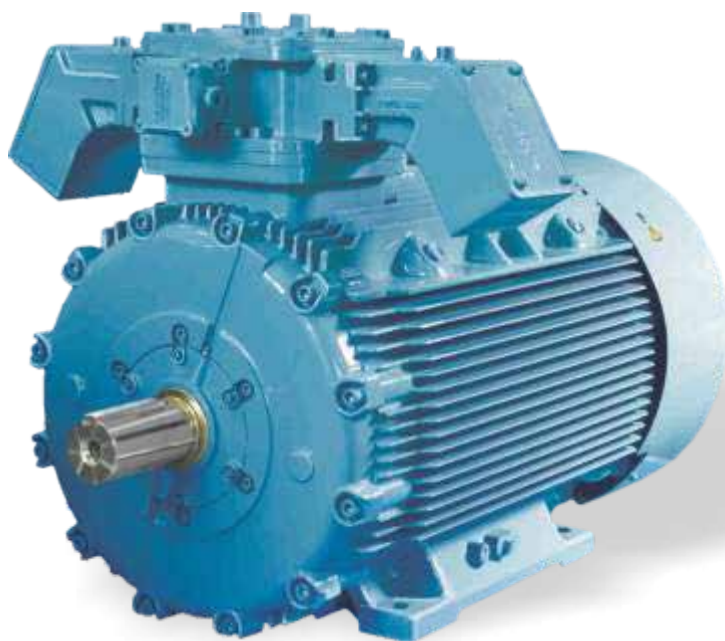

Smart solutions.
Strong relationships.

Premium Efficiency LV AC Flame Proof Motors IE2 / IE3 Efficiency Class



Apex Series
a green solution

We put all our energy into saving yours !



Save today, for better tomorrow.

Out of total electricity generated worldwide, it is estimated that between 30 to 40 % is consumed by industrial electric motors. Given the global concern about diminishing resources, and recent high prices for energy, it is no wonder that there is increasing interest in the energy efficiency of electric motors. Of course the electric motor is only one element in a motor-driven system that offers the potential for savings, but it has been estimated that optimizing motor-driven systems could deliver overall savings of between 30 and 60 per cent.

Apex series, IE3 premium efficiency LV motors, is another green initiative by CG to save energy.

“Saving 1 kWh of electricity produced from a thermal power station saves average 0.82kg of CO₂ emission to the atmosphere”.







Apex Series

a green solution

IT'S JUST NOT A BRAND,
IT'S A SYMBOL OF ENERGY SAVINGS



CERTIFIED BY



DGMS



PESO



CSA



Crompton Greaves

CG is a pioneer in the management and application of electrical energy. With more than 15,000 employees across its operations around 85 countries, CG provides electrical products, systems and services for utilities, power generation, industries, and consumers. The company is organized into four business groups: Power, Industrial, Automation, and Consumer, with a revenue of US\$ 2.3 billion from product lines that cover the entire value chain of engineering offerings.

CG is engaged in design, manufacturing and marketing of electric motors for last 75 years. Our products are used in almost every industrial application including manufacturing, petrochemicals, food processing, pharmaceuticals where they drive fans, pumps, compressors, conveyors, lifts and cranes. Our core competencies lie in our design facility conforming to the international quality standards. We make continuous effort to bring out the latest, most advanced products into market-place. We continuously add many new services, features and introduce new solutions so as to ensure complete customer satisfaction.

Quality assurance

Stringent quality procedure is observed from first design to finish product in accordance with international quality systems. All of our manufacturing facilities have accredit with ISO 9001 OHSAS 18001 & ISO 14001 been assessed to meet these requirements, a further assurance that only the highest possible standards of quality are accepted.

CG flame proof motors

CG has the widest manufacturing range of low voltage motors suitable for hazardous area. These motors are designed to suit the ignitable atmospheres present in hazardous locations such as Zone 1, Zone 2. Motors are suitable for various temperature classes & gas groups.

We have technical and design expertise in this very specialize market and are able to ensure the correct selection of motors for any application taking into account of two most important factors to be considered safety and compliance to various statutory norms of various countries.

CG flame proof motors are designed tested and manufactured in accordance with latest national and international standards, following are the salient features offered:

Salient features

- Rugged cast iron construction
- Low vibration and noise
- Excellent aesthetics
- Motors are with metallic fan
- Specially designed cooling fins for better heat dissipation
- Rigid foot construction for low vibration
- IP66 protection
- Bigger terminal box for proper termination of cables

Optional features

- Suitable for operation with VFD*
- Motors can be offered with plug and socket
- Specially designed terminal box to accommodate 3 nos of auxiliary boxes
- Encoder and external fan arrangement
- Mild steel enclosure can also be offered as per request
- temperature range -20 deg. To 60 deg.
- Special slip ring flame proof motors for mine application
- Special mine ventilation flame proof motors

Construction

Crompton greaves flame proof motors are made up of High quality cast iron construction, ribbed externally to ensure maximum heat dissipation. All components are machined on CNC machines ensuring concentricity and correct alignment. The windings and working parts are completely enclosed and air is forced over the stator body by fan, mounted on the shaft and protected by a cowl. The feet are integrally cast with the body. This ensures sturdiness and resistance to vibrations. Explosion-proof Ex'd-A type of protection that utilizes an enclosure that is capable of withstanding an explosive gas or vapor within it and or preventing the ignition of an explosive gas or vapor that may surround it and that operates at such an external temperature that a surrounding explosive gas or vapor will not be ignited thereby.

Stator and rotor cores

Both the stator and rotor cores consist of low loss and high Permeability steel stampings which are assembled under pressure and rigidly secured by end plates.

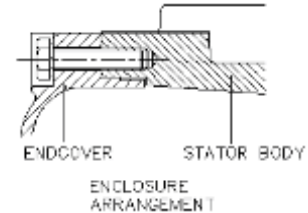

Terminal Box

Terminal box is provided with IP55 degree of protection. The box can be turned through 360 in steps of 90 to give cable entry from any one of four positions

Following are the additional features:

- High grade cast iron construction capable of containing internal explosion
- Specially designed for accommodating bigger cables and proper termination
- Double decker terminal arrangement for easy termination of two cables
- Anti loosening terminal arrangement

For slip ring motors, separate terminal box for stator & rotor terminations provided. Stator terminal box is on left hand side while rotor terminal box is on right hand side viewed from driving end.

Terminal Stud

Terminal stud for CG flame proof motors comes up with following features:

- Fully non hygroscopic thermosetting moulded glass filled compound.
- Increased clearances & creepages.
- Anti loosening arrangement.
- Metallic bush insert to take tightening pressure. Eliminates breakage of insulation (E160-315LX frames)

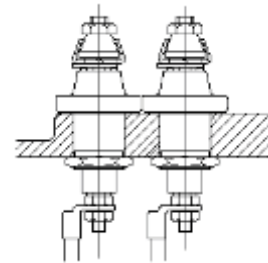

Insulation system

Crompton Greaves flame proof motors are designed and manufactured with carefully selected and tested insulating materials to ensure long services. The life of the motor mostly depends upon the life of the insulating materials since bearings, brush gears, slip rings etc. can be replaced easily during normal maintenance.

Motors are provided with class F insulation with temperature rise limited to class B, gel coat is provided on over hang as additional protection against ingress of moisture

Winding

Stator winding (and rotor winding in case of slip ring motors) consists of enameled copper wire impregnated with superior quality class F varnish which is rigid at all working temperatures.

Stator in motors with frame 280 & above are manufactured with vacuum pressure impregnation process as a standard. All rotors irrespective of frame size are processed with vacuum pressure impregnation. This gives added electrical & mechanical strength to the winding for high number of starts. The varnish has a high insulation resistance and excellent resistance to moisture, saline atmosphere, acidic / alkaline fumes, and also to oil and grease. The insulation gives complete reliability under all atmospheric conditions, including humid tropical climates. Stator and rotor wound packs are subjected to surge test before impregnation.

Reasons to buy Apex series...

LOW OPERATING COST



APEX series IE3 motors are complying with new efficiency requirement of IEC60034-30:2008 with lowest payback and low operating cost.



LOW VIBRATION

IEC Standard? We set our own standard for vibration much lower than IEC 60034-14.

Rotors are dynamically balanced to G 2.5 class at rated speed ensuring low vibration level.

VIBRATION LOWER THAN IEC

Frames	IEC60034-14	CGL
63 - 132	1.6	0.4-1.2
160-280	2.2	1.1-1.8
280 & Above	2.8	1.8-2.0

mm / Sec.



Balancing Machine





SUPERIOR AESTHETICS

APEX series motors are having superior aesthetics, with RAL 5021 standard paint shade. We can provide various paint shade and painting scheme according to project requirement including C3M, C4M, & C5M.

Frames (cast iron range) are constructed using high grade FG250 cast iron, ribbed externally to ensure maximum heat dissipation.

Apex series motor is fitted with terminal box and gives IP55 degree of protection. The box can be rotated through 360 degree in steps of 90 degree to give cable entry from any of four positions. Terminal box is designed to provide more space for proper termination of cables inside terminal box.

ENGINEERED TO APPLICATION

Apex series motors can be offered with add on accessories like anti condensation heaters, insulated bearings, encoder mounting arrangements etc.

CG Apex series motors are 100% in house manufactured from its own stamping, diecast and winding centers.

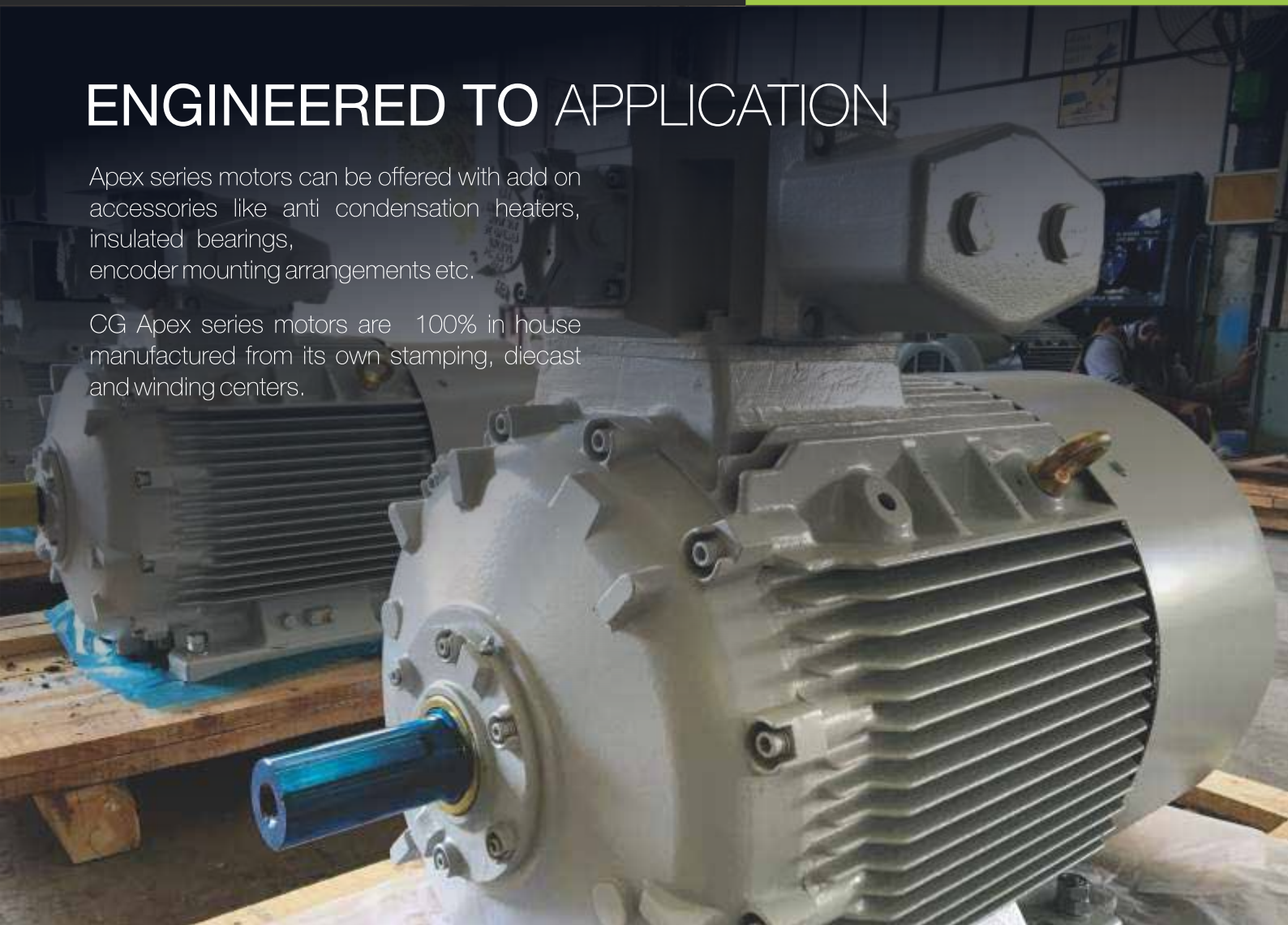

STATE OF THE ART TESTING FACILITY

IEC has adopted testing procedure from CSA, IEEE 112-method B i.e measurement of efficiency by actual stray load losses calculation.

It is well known that induction motor testing standards vary significantly in their defined methodologies, instrumentation accuracy, and testing procedures. Sometimes, the efficiency value for the same motor can differ by 5% with different standards. Even though the same standard is used in experimental tests, the machine efficiency can still vary by more than 2 % when performed in different testing sites.

So it becomes important to keep regular check on instrumentation accuracy and testing procedure to ensure guaranteed efficiency.

Our 7 test labs with 0.2 class instrumentation and torque transducers are approved by CSA for accuracy and testing procedure under CPC programme.

In order to qualify for the CPC program, you will need to obtain a certificate of qualification from CSA Group demonstrating:

- Complete knowledge of all applicable product standards
- The ability to design, manufacture and test products that comply with those standards
- Access to suitable testing facilities

**ONLY MOTOR MANUFACTURER IN INDIA TO
HAVE THIS APPROVAL AS PER ISO/IEC 17025:2015
APPROVED BY CSA (CANADIAN STANDARDS AUTHORITY)**



Applicable National/ international standards for Hazardous area Motors

Standards	Description
IS/IEC 60034-1:2010	Rotating electrical machines - Part 1 Rating and performance
IS/IEC 60079-1:2007	Electrical apparatus for Explosive gas atmosphere - Equipment protection by flame proof enclosures "d"
IS/IEC 60079-0:2004	Electrical apparatus for Explosive gas atmosphere Part 0 General Requirements
IEC 60079-15:2010	Electrical Apparatus for explosive gas atmosphere - Construction, test & marking of type of protection "n" electrical apparatus.
IS/IEC 60079-7 Part 7:	Equipment protection by increased safety 'e'
IEC 60072-1:1991	Dimension & output ratings of rotating electrical machines
IEC 60034-30:2014	Efficiency classes of single speed, three phase, cage induction motors
IEC 60034-9:2007	Rotating electrical machines - Noise limits
IEC 60034-14:2007	Rotating electrical machines, Vibration limits
IS 325	Three phase Induction motors-specification
IS 5572:2009	Classification of hazardous areas (other than mines) having flammable gases and vapors for electrical installations.
IS 15142:2002	Guide to the use of electrical apparatus for potentially explosive atmosphere in the presence of combustible dust.
IS 5571:2009	Guide for selection and installation of electrical equipment for hazardous areas (other than mines)
IS : 1231:1974	Dimensions of foot mounted A.C induction motors
IS : 2223:1983	Dimensions of flange mounted A.C induction motors

Certificates/approvals		CG offering		
		Enclosure	Gas group	Range
BASEEFA	Notified agency for testing & certification (for Atex, IECEx)	Type 'd'	IIA IIB	E80 to E315
DGMS	Regulatory body Govt. of india for approvals of installation of products in mines	Type 'd'	I	E90 to E315
		Type 'd'	IIA IIB	E90 to E315
PESO	Statutory authority Govt.of India for framing rules/ acts for equipment used in petroleum /explosive area	Type 'd'	IIA IIB IIC	E80 to E355
		Type 'e'	IIC	ND80 to ND355
		Type 'n'	IIC	ND80 to ND355
BIS	National Standards Body of India, issues licenses	Type 'd'	I IIA IIB	E80 to E355

Classification of explosive atmospheres according and IEC

The following standards define areas according to the presence of gas or dust in the atmosphere:
 IEC/EN 60079-10-1 Gas
 IEC/EN 60079-10-2 Dust

Type of Enclosures

- Ex 'd'** [Flameproof enclosure in accordance with IEC 60079-1](#)
 Machines constructed to contain an internal explosion and prevent the transmission of flame to the external Atmosphere.
 Operating temperature is such that it cannot ignite any surrounding gases.
 Applicable zones: Zone 1 and 2
- Ex 'n'** [Non-sparking in accordance with IEC 60079-15](#)
 Machines constructed to contain an internal explosion and prevent the transmission of flame to the external Atmosphere.
 Operating temperature is such that it cannot ignite any surrounding gases.
 Applicable zones: Zone 1 and 2
- Ex 'e'** [Increased safety in accordance with IEC 60079-7](#)
 Machines that do not emit dangerous sparks or temperatures when starting or during normal operation. Special additional safety measures are taken.
 Applicable zones: Zone 1 and 2

Zone 0 (Gas) / 20 (Dust)
 Continuously
 Permanent presence of explosive atmosphere

Zone 1 (Gas) / 21 (Dust)
 Occasionally
 Incidental presence of explosive atmosphere during normal duty

Zone 2 (Gas) / 22 (Dust)
 Abnormal condition
 Presence of explosive atmosphere only by accident, but not during normal duty

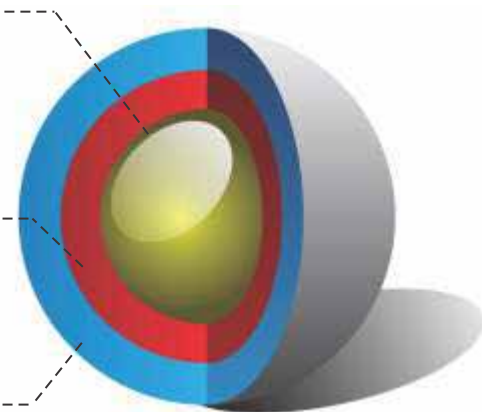

Hazardous Areas

According to IEC 60079-10 standard, Explosive Atmosphere is a "mixture with air, under atmospheric conditions, of flammable substances in the form of gas, vapors, dust, fibers, or flyings which, after ignition, permits self-sustaining propagation". Hazardous Area is "an area in which an explosive atmosphere is or may be expected to be present, in quantities such as to require special precautions for the construction, installation and use of equipment". For this reason, motors with explosion proof protection are built in such a way to not allow the explosion in the hazardous areas, where they are installed. Explosions may occur either due to the transfer of flames or overheating. The hazardous areas are classified per zones, groups and temperature classes, according to the International Electrotechnical Commission (IEC) and National Electrical Committee (NEC).

Temperature classification

A mixture of hazardous gases and air may be ignited by coming into contact with a hot surface. The conditions under which a hot surface will ignite a gas depend on surface area, temperature, and the concentration of the gas. The same can be said about combustible dusts. The T code of a product denotes the maximum surface temperature that a given product will not exceed under a specified ambient temperature. For example, a product with a T code of T3 means that its maximum surface temperature will not exceed 200°C provided it is operated in a ambient temperature defined by the manufacturer.

Temp. Class as per IS:3681 and IEC 79-7	Ignition Temperature -°C	
	Above	Upto and including
T1	450	-
T2	300	450
T3	200	300
T4	135	200
T5	100	135
T6	85	100

If a hazardous is present the equipment used with in the installation must be given an appropriate T classification in order to maintain the integrity. If that hazardous is, say, hydrogen, then all equipment used must meet the T6 rating. This means that all equipment used must not have a surface temperature of greater than 85°C. Any equipment used that can generate a hotter surface temperature of greater than 85°C must not be used as this will then increase the likelihood of an explosion by igniting the hydrogen in the atmosphere.

Classification of hazardous gases :

Hazardous gases have been classified in IS:2148, VDE 0171 & 5572 (Pt 1) and are associated only with flame proof enclosures. These gases are listed in Table 3.

Note : Flame proof motors are offered suitable for Gas Groups I, IIA & IIB only. For gases not mentioned, please refer the relevent Indian Standards.

Gas Group	Gas or Vapour	Temp. Class.
I	Methane (Firedamp)	T1
II A	Ammonia	T1
	Industrial methane*	T1
	Carbon monoxide	T1
	Propane	T1
	Butane	T2
	Benzene	T1
	Cyclohexane	T2
	Acetone	T1
	Ethyl acetate	T1
	Amyl acetate	T2
II B	Methanol	T1
	Ethanol	T2
	n-Butanol	T2
	1, 3 – Butadiene	T2
	Ethylene	T2
	Diethyl ether	T4
	Ethylene oxide	T2
II C	Coke-oven gas	T1
	Hydrogen	T1



LV FLAME PROOF MOTORS

STANDARDS & CERTIFICATIONS

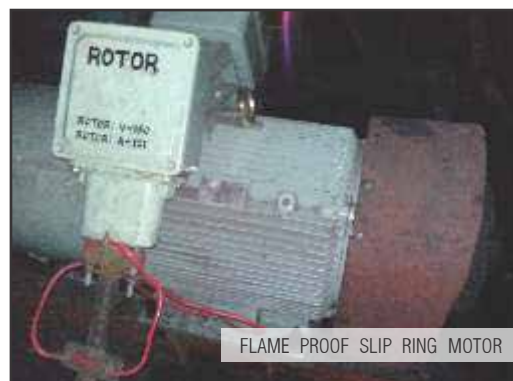
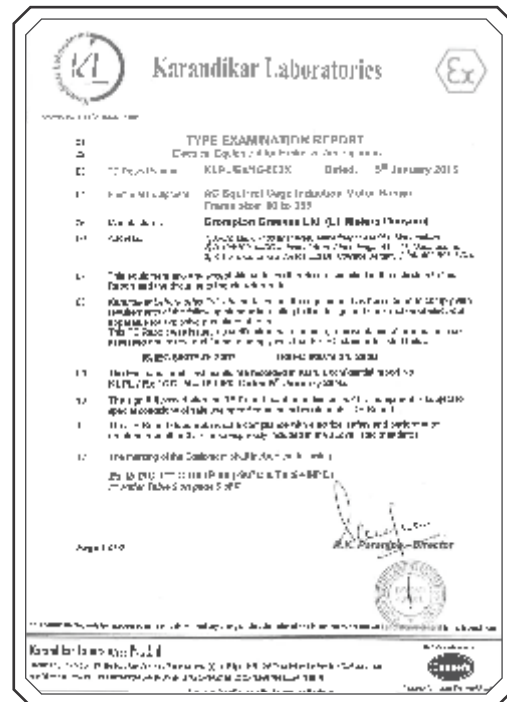
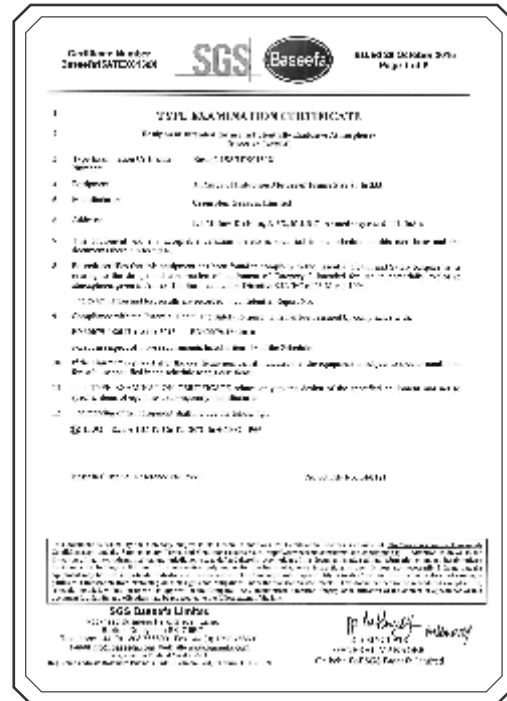

IECEx Certificate of Conformity

INTERNATIONAL ELECTROTECHNICAL COMMISSION
IEC Certification Scheme for Explosive Atmospheres
For rules and details of the IECEx Scheme visit www.iecex.com

Certificate No.: **IECEx BAS 14.D.14.01** Issue No.: **1** Certificate history: **.....**

Status: **Current**

Date of issue: **2015-03-17** Page 1 of 3

Applicant: **Crompton Greaves Limited
LT Motors Division
4-62, MIDC
Ammalgaon 414111
Maharashtra
India**

Electrical Apparatus: **The E89 to E102 Squirrel Cage Induction Motors**
Optional accessories:

Type of Protection: **Flameproof**

Marking: **Ex db IIC T1 Gb IP66 (-20°C to 55°C) – See schedule 1****

Approved for issue on behalf of the IECEx Certification Body: **R. S. Srinivas**

Position: **Technical Manager**

Signature: *(for printed version)* **[Signature]** **M. B. Srinivas**

Date: **17/3/15**

1. This certificate and schedule may only be reproduced in full.
2. This certificate is not transferable and remains the property of the issuing body.
3. The Status and authenticity of this certificate may be verified by visiting the Official IECEx Website.

Certificate issued by: **SGS Baseefa Limited
Rushmore Business Park
Staden Lane
Bardon
Derbyshire
S17 9SD
United Kingdom**

SGS Baseefa

IECEx Certificate of Conformity

INTERNATIONAL ELECTROTECHNICAL COMMISSION
IEC Certification Scheme for Explosive Atmospheres
For rules and details of the IECEx Scheme visit www.iecex.com

Certificate No.: **IECEx BAS 14.D.11.05X** Issue No.: **1** Certificate history: **.....**

Status: **Current**

Date of issue: **2015-03-17** Page 1 of 3

Applicant: **Crompton Greaves Limited
LT Motors Division
4-62, MIDC
Ammalgaon 414111
Maharashtra
India**

Electrical Apparatus: **The E100 to E130 Squirrel Cage Induction Motors**
Optional accessories:

Type of Protection: **Flameproof**

Marking: **Ex db IIC T1 Gb IP66 (-20°C to 55°C) – See schedule 1****

Approved for issue on behalf of the IECEx Certification Body: **R. S. Srinivas**

Position: **Technical Manager**

Signature: *(for printed version)* **[Signature]** **M. B. Srinivas**

Date: **17/3/15**

1. This certificate and schedule may only be reproduced in full.
2. This certificate is not transferable and remains the property of the issuing body.
3. The Status and authenticity of this certificate may be verified by visiting the Official IECEx Website.

Certificate issued by: **SGS Baseefa Limited
Rushmore Business Park
Staden Lane
Bardon
Derbyshire
S17 9SD
United Kingdom**

SGS Baseefa

IECEx Certificate of Conformity

INTERNATIONAL ELECTROTECHNICAL COMMISSION
IEC Certification Scheme for Explosive Atmospheres
For rules and details of the IECEx Scheme visit www.iecex.com

Certificate No.: **IECEx BAS 14.D.11.05Z** Issue No.: **1** Certificate history: **.....**

Status: **Current**

Date of issue: **2015-03-17** Page 1 of 3

Applicant: **Crompton Greaves Limited
LT Motors Division
4-62, MIDC
Ammalgaon 414111
Maharashtra
India**

Electrical Apparatus: **The E225 to E235 Squirrel Cage Induction Motors**
Optional accessories:

Type of Protection: **Flameproof**

Marking: **Ex db IIC T1 Gb IP66 (-20°C to 55°C) – See schedule 1****

Approved for issue on behalf of the IECEx Certification Body: **R. S. Srinivas**

Position: **Technical Manager**

Signature: *(for printed version)* **[Signature]** **M. B. Srinivas**

Date: **17/3/15**

1. This certificate and schedule may only be reproduced in full.
2. This certificate is not transferable and remains the property of the issuing body.
3. The Status and authenticity of this certificate may be verified by visiting the Official IECEx Website.

Certificate issued by: **SGS Baseefa Limited
Rushmore Business Park
Staden Lane
Bardon
Derbyshire
S17 9SD
United Kingdom**

SGS Baseefa

IECEx Certificate of Conformity

INTERNATIONAL ELECTROTECHNICAL COMMISSION
IEC Certification Scheme for Explosive Atmospheres
For rules and details of the IECEx Scheme visit www.iecex.com

Certificate No.: **IECEx BAS 14.D.11.05A** Issue No.: **1** Certificate history: **.....**

Status: **Current**

Date of issue: **2015-03-17** Page 1 of 3

Applicant: **Crompton Greaves Limited
LT Motors Division
4-62, MIDC
Ammalgaon 414111
Maharashtra
India**

Electrical Apparatus: **The E235 Squirrel Cage Induction Motor**
Optional accessories:

Type of Protection: **Flameproof**

Marking: **Ex db IIC T1 Gb IP66 (-20°C to 55°C) – See schedule 1****

Approved for issue on behalf of the IECEx Certification Body: **R. S. Srinivas**

Position: **Technical Manager**

Signature: *(for printed version)* **[Signature]** **M. B. Srinivas**

Date: **17/3/15**

1. This certificate and schedule may only be reproduced in full.
2. This certificate is not transferable and remains the property of the issuing body.
3. The Status and authenticity of this certificate may be verified by visiting the Official IECEx Website.

Certificate issued by: **SGS Baseefa Limited
Rushmore Business Park
Staden Lane
Bardon
Derbyshire
S17 9SD
United Kingdom**

SGS Baseefa

LV FLAME PROOF MOTORS

GENERAL SPECIFICATION

IEC IE2/IE3 Ex'd' motors (Cast iron Frames)



Range	
Output	0.18kW to 325 kW
Frames	E80 to E355
Poles	2,4,6

Specification						
	Standard Product		Option			
Frame sizes	E80 to E355 (Ex'd' type)		-			
Enclosure	IP55		IP66			
Zone	1					
Gas group	I IIA IIB IIC					
Temperature class	T4		T3 TO T6			
Duty	S1		S2 TO S9			
Mounting	B3		Optional			
			Frame	Mounting		
			Upto 132	B5, B35, B14, B34, V1		
		160 to 315	B5,B35,V1			
Terminal Box Material	Cast iron		--			
Shaft material	EN8		EN24			
Voltage	Upto 3kW	415V λ	other on request			
	Above 3kW	415V Δ				
Frequency	50Hz		60HZ*			
Cooling	IC411					
Insulation	Class F		Class H			
Thermal protection	--		E90 to E355			
Anti condensation heater	--		E160 to E355			
Paint	Epoxy anti corrosive paint surface		Other on request			
Inverter duty(With deration)*	--		E80 to E355			
			Other on request, Permissible output as % of			
Ambient Temperature	-20°C to 45°C		Standard output at different Ambient			
			45°C	50°C	55°C	60°C
			100%	92%	85%	78%
Altitude	<1000					
Approvals	DGMS, PESO, (ATEX, IECEX)					

*For more details on VFD compatible flame proof motors please contact CG sales

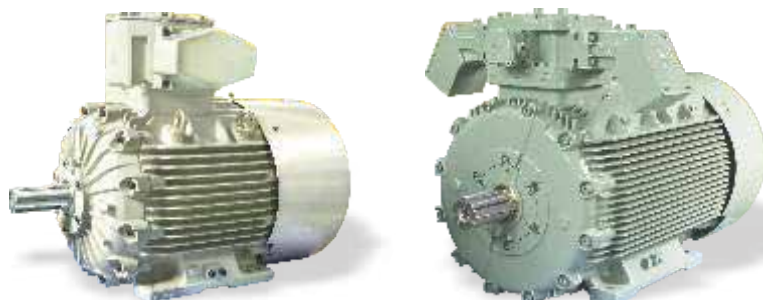



PERFORMANCE DATA FOR APEX SERIES MOTOR
Efficiency Values Complying To IE2 Class Of IEC60034-30:2014

OUTPUT		FRAME	FULL LOAD CURRENT (AMP)			FL	FLT	EFFICIENCY			POWER FACTOR			D.D.L STARTING		POT %FLT	GD ² KGM ²
KW	HP		IN			RPM	Kg -m	FL	3/4L	1/2L	FL	3/4L	1/2L	STT %FLT	SCC %FLA		
			380 V	400 V	415V												

2 POLE : 3000 RPM

0.37	0.50	E80	0.9	0.9	0.9	2880	0.125	72.2	72	65	0.82	0.8	0.7	250	600	300	0.003
0.55	0.75	E80	1.4	1.3	1.3	2870	0.187	75.0	75	72	0.8	0.74	0.7	225	600	275	0.003
0.75	1.00	E80	1.8	1.7	1.7	2770	0.264	77.4	75.4	70.4	0.81	0.72	0.65	240	650	280	0.004
1.1	1.50	E90L	2.6	2.4	2.3	2870	0.373	79.6	79.6	77	0.82	0.75	0.62	325	650	350	0.010
1.5	2.00	E90L	3.4	3.2	3.1	2870	0.51	81.3	81.3	81.3	0.82	0.75	0.62	250	650	300	0.01
2.2	3.00	E90L	5.2	4.9	4.7	2900	0.74	83.2	83	79	0.78	0.71	0.61	300	700	350	0.01
3	4.00	E100L	6.1	5.8	5.6	2900	1.01	84.6	84.6	82.0	0.88	0.84	0.78	225	650	275	0.03
3.7	5.00	E100L	7.8	7.4	7.2	2890	1.2	85.5	85.5	82	0.84	0.8	0.72	250	650	300	0.03
4	5.50	E112M	8.0	7.6	7.4	2910	1.3	85.8	85.8	84	0.88	0.84	0.75	225	700	275	0.04
5.5	7.50	E132M	11	10	10	2910	1.8	87.0	87	85	0.88	0.84	0.8	200	650	250	0.10
7.5	10.00	E132M	15	14	14	2920	2.5	88.1	88	86	0.86	0.82	0.76	250	700	300	0.11
9.3	12.50	E160L	18	17	17	2920	3.1	88.8	88.8	86.0	0.88	0.85	0.81	250	650	300	0.14
11	15.00	E160L	21	20	19	2925	3.7	89.4	89.4	87.0	0.9	0.86	0.82	225	700	275	0.17
15	20.00	E160L	29	27	26	2920	5.0	90.3	90.3	89.0	0.88	0.85	0.78	250	700	300	0.17
18.5	25.00	E160L	35	33	32	2920	6.2	90.9	90.9	89.2	0.88	0.85	0.8	200	700	300	0.21
22	30.00	E180L	41	39	38	2940	7.3	91.3	91.3	90.5	0.89	0.85	0.77	250	700	300	0.44
30	40.00	E200L	56	53	51	2945	9.9	92.0	92.0	91.0	0.89	0.86	0.82	180	700	225	0.78
37	50.00	E200L	69	66	63	2945	12.2	92.5	92.5	92.0	0.88	0.86	0.81	160	650	200	0.78
45	60.00	E225M	87	82	79	2960	14.8	92.9	92.6	91.5	0.85	0.8	0.78	200	700	250	1.87
55	75.00	E250M	97	93	89	2970	18.0	93.2	93	91.5	0.92	0.88	0.84	250	700	300	3.40
75	100.00	E280M	132	125	121	2975	24.5	93.8	93	91.5	0.92	0.88	0.84	200	650	250	6.65
90	120.00	E280M	155	147	142	2975	29.5	94.1	94	92.1	0.94	0.9	0.82	175	650	225	6.65
110	150.00	E315M	199	189	182	2980	35.9	94.3	94.3	93	0.89	0.85	0.81	200	700	250	13.31
132	180.00	E315M	236	224	216	2970	43.3	94.6	94	93	0.9	0.88	0.85	175	600	225	13.31
160	215.00	E315L	288	274	264	2977	52.3	94.8	94.6	94	0.89	0.85	0.81	200	700	250	14.75
180	240.00	E315L	320	304	293	2977	58.9	95.0	95	94	0.9	0.85	0.81	200	700	250	16.37
200	270.00	E315L	348	330	318	2980	65.3	95.0	95	93.8	0.92	0.9	0.87	200	750	250	16.37
225	300	E355LX	395	376	362	2980	98.1	95.0	94.6	94.2	0.91	0.88	0.84	160	650	225	16.370
250	335	E355LX	444	422	407	2980	109.5	95.0	94.8	94.2	0.90	0.88	0.84	150	650	225	18.350
275	370	E355LX	494	469	452	2980	120.9	95.0	94.8	94.2	0.89	0.86	0.82	200	650	250	18.350

FL = Full Load; FLC = Full Load Current; FLT = Full Load Torque
 SGT. T = Starting Torque; SGT. C = Starting Current

* Tolerances are applicable as per IEC 60034-1 : 2004
 Full load current indicated are given for respective voltage designs



PERFORMANCE DATA FOR APEX SERIES MOTOR
Efficiency Values Complying To IE2 Class Of IEC60034-30:2014

OUTPUT		FRAME	FULL LOAD CURRENT (AMP)			FL	FLT	EFFICIENCY			POWER FACTOR			D.D.L STARTING		POT %FLT	GD ² KGM ²
KW	HP		IN			RPM	Kg -m	FL	3/4L	1/2L	FL	3/4L	1/2L	STT %FLT	SCC %FLA		
			380 V	400 V	415V												

4 POLE : 1500 RPM

0.37	0.5	E80	1.0	1.0	0.9	1430	0.252	75.0	72	70	0.73	0.66	0.6	175	500	225	0.004
0.55	0.8	E80	1.5	1.4	1.3	1420	0.377	77.0	77	75	0.74	0.67	0.55	175	500	225	0.007
0.75	1.0	E80	2.0	1.9	1.8	1410	0.518	79.6	79	76	0.73	0.66	0.55	200	500	250	0.007
1.1	1.5	E90L	2.8	2.7	2.6	1430	0.749	81.4	81.4	79	0.73	0.67	0.52	200	600	250	0.022
1.5	2.0	E90L	3.9	3.7	3.6	1430	1.021	82.8	82.8	80	0.7	0.65	0.54	200	600	250	0.022
2.2	3.0	E100L	5.1	4.8	4.7	1450	1.477	84.3	84.3	82	0.78	0.7	0.6	200	600	250	0.047
3.7	5.0	E112M	8.4	7.9	7.6	1450	2.5	86.3	86.3	84	0.78	0.74	0.66	200	600	250	0.090
5.5	7.5	E132M	11	11	10	1460	3.7	87.7	87.7	86	0.85	0.8	0.75	200	650	250	0.26
7.5	10.0	E132M	15	15	14	1457	5.0	88.7	88.7	87.2	0.83	0.77	0.66	225	650	275	0.26
9.3	12.5	E160L	19	18	17	1470	6.2	89.3	89.3	88.0	0.85	0.8	0.7	250	700	300	0.39
11	15.0	E160L	22	21	20	1470	7.3	89.8	89.8	88.5	0.86	0.81	0.72	225	700	250	0.45
15	20.0	E160L	31	30	29	1465	10.0	90.6	90.6	90	0.8	0.72	0.61	200	650	250	0.48
18.5	25.0	E180L	35	33	32	1470	12.3	91.2	91.2	90.5	0.89	0.86	0.8	200	600	250	0.81
22	30.0	E180L	42	40	39	1470	14.6	91.6	91.6	89	0.86	0.82	0.75	225	600	275	0.85
30	40.0	E200L	57	55	53	1475	19.8	92.3	92.3	92	0.86	0.82	0.76	200	650	250	1.62
37	50.0	E225S	74	70	68	1470	24.5	92.7	92.7	92	0.82	0.75	0.72	200	600	250	2.70
45	60.0	E225M	82	78	75	1475	29.7	93.1	93.1	92.8	0.9	0.85	0.8	225	650	275	3.13
55	75.0	E250M	102	96	93	1480	36.2	93.5	93.5	93.0	0.88	0.84	0.8	225	600	275	6.28
75	100.0	E280M	133	127	122	1485	49.2	94.0	94.0	93.0	0.91	0.88	0.84	200	650	250	11.6
90	120.0	E280M	165	157	151	1485	59.0	94.2	94.2	94	0.88	0.84	0.8	200	700	250	11.6
110	150.0	E315M	194	185	178	1488	72.0	94.5	94.5	93.5	0.91	0.88	0.82	200	600	250	20.3
132	180.0	E315M	235	224	215	1490	86.2	94.7	94	93.2	0.9	0.86	0.8	180	650	225	20.3
160	215.0	E315L	281	267	258	1488	104.7	94.9	94.9	94.1	0.91	0.88	0.85	200	650	250	26.6
180	240.0	E315L	316	301	290	1488	117.8	95	95	94.2	0.91	0.88	0.85	225	700	275	26.6
200	270.0	E315L	347	330	318	1489	130.8	95.1	95.1	94.7	0.92	0.9	0.86	200	700	250	28.0
225	300.0	E355LX	399	379	366	1490	196.1	95.1	95.1	94.0	0.90	0.88	0.84	150	600	225	29.600
250	335.0	E355LX	444	422	406	1490	219.0	95.1	95.1	94.0	0.90	0.86	0.81	180	800	225	30.000
275	370.0	E355LX	478	454	437	1485	242.7	95.1	95.1	94.0	0.92	0.88	0.84	175	700	225	32.000

FL = Full Load; FLC = Full Load Current; FLT = Full Load Torque
 SGT. T = Starting Torque; SGT. C = Starting Current

* Tolerances are applicable as per IEC 60034-1 : 2004
 Full load current indicated are given for respective voltage designs



PERFORMANCE DATA FOR APEX SERIES MOTOR
Efficiency Values Complying To IE2 Class Of IEC60034-30:2014

OUTPUT		FRAME	FULL LOAD CURRENT (AMP)			FL	FLT	EFFICIENCY			POWER FACTOR			D.D.L STARTING		POT %FLT	GD ² KGM ²
KW	HP		IN		FL (AMP)	RPM	Kg -m	FL	3/4L	1/2L	FL	3/4L	1/2L	STT %FLT	SCC %FLA		
			380 V	400 V	415V												

6 POLE : 1000 RPM

0.75	1.00	E90L	2.3	2.2	2.1	935	1.0	75.9	75.9	74	0.65	0.56	0.48	175	500	225	0.020
1.1	1.50	E90L	3.1	2.9	2.8	935	1.6	78.1	77.5	76	0.69	0.6	0.47	180	500	250	0.024
1.5	2.00	E100L	4.4	4.2	4.0	940	2.1	79.8	79.5	77	0.65	0.59	0.48	200	500	250	0.054
2.2	3.00	E112M	5.8	5.5	5.3	960	3.0	81.80	81.00	79.00	0.7	0.66	0.56	200	550	250	0.069
3.7	5.00	E132M	8.1	7.7	7.4	960	5.1	84.3	84.3	83	0.82	0.76	0.64	175	550	250	0.185
5.5	7.50	E132M	13	12	11.9	965	7.6	86	86	84	0.75	0.7	0.6	175	550	250	0.400
7.5	10.00	E160L	16	15	14	975	10.0	87.2	87	87	0.84	0.76	0.64	225	600	275	0.460
11	15.00	E160L	22	21	21	975	15.0	88.7	88.7	87	0.84	0.75	0.65	200	600	250	0.590
15	20.00	E180L	33	31	30	975	20.0	89.7	89.7	88	0.78	0.71	0.58	225	600	250	0.640
18.5	25.00	E200L	37	35	34	975	25.0	90.4	90.4	89.2	0.84	0.8	0.72	200	600	250	1.160
22	30.00	E200L	44	42	40	975	30.0	90.9	90.5	89	0.84	0.8	0.7	200	550	250	1.690
30	40.00	E225M	58	56	54	980	39.8	91.7	91.7	91	0.85	0.81	0.73	200	600	250	2.040
37	50.00	E250M	73	69	66	975	49.9	92.2	92.2	90.5	0.84	0.8	0.78	200	600	250	3.610
45	60.00	E280M	90	85	82	988	59.1	92.7	92.7	92	0.82	0.78	0.7	200	650	250	4.820
55	75.00	E280M	111	105	101	990	73.8	93.1	93.1	92.2	0.81	0.78	0.74	200	700	250	8.010
75	100.00	E315M	141	134	129	990	98.4	93.7	93.2	91	0.86	0.82	0.74	160	600	200	9.890
90	120.00	E315M	169	161	155	990	118.1	94	93.5	91.8	0.86	0.82	0.74	175	600	225	14.120
110	150.00	E315L	206	196	189	985	148.3	94.3	94.3	92.3	0.86	0.82	0.74	175	600	225	17.000
132	180.00	E315L	247	234	226	990	177.1	94.6	94.6	93.6	0.86	0.82	0.74	200	600	250	18.980
160	215.00	E355L	298	283	273	990	211.5	94.8	94.8	92	0.86	0.82	0.74	200	600	250	20.740
180	240.00	E355L	331	315	303	990	236.1	94.9	94.9	94.5	0.87	0.85	0.78	175	600	250	21.900
200	270.00	E355L	376	357	345	990	265.6	95.0	95.0	94.5	0.85	0.81	0.75	130.00	600	225	23.22

FL = Full Load; FLC = Full Load Current; FLT = Full Load Torque
 SGT. T = Starting Torque; SGT. C = Starting Current

* Tolerances are applicable as per IEC 60034-1 : 2004
 Full load current indicated are given for respective voltage designs



PERFORMANCE DATA FOR APEX SERIES MOTOR
Efficiency Values Complying To IE3 Class Of IEC60034-30:2014

OUTPUT		FRAME	FULL LOAD CURRENT (AMP)			FL	FLT	EFFICIENCY			POWER FACTOR			D.D.L STARTING		POT %FLT	GD ² KGM ²
KW	HP		IN			RPM	Kg -m	FL	3/4L	1/2L	FL	3/4L	1/2L	STT %FLT	SCC %FLA		
			380 V	400 V	415V												

2 POLE : 3000 RPM

0.75	1.00	E80	1.7	1.7	1.6	2770	0.26	80.7	80.7	80.3	0.81	0.72	0.65	240	650	280	0.000
1.10	1.50	E90L	2.5	2.3	2.2	2890	0.37	82.7	82.7	82.0	0.82	0.76	0.63	325	650	375	0.010
1.50	2.00	E90L	3.2	3.0	2.9	2890	0.51	84.2	84.2	83.5	0.85	0.80	0.75	250	650	300	0.014
2.20	3.00	E90L	4.8	4.6	4.4	2910	0.74	85.9	85.3	83.1	0.81	0.73	0.61	300	700	350	0.014
3.00	4.00	E100L	5.9	5.6	5.4	2910	1.00	87.1	87.1	87	0.88	0.85	0.78	225	650	275	0.028
3.70	5.00	E100L	7.5	7.2	6.9	2890	1.25	87.8	88.10	88.10	0.85	0.82	0.74	250	650	300	0.028
4.00	5.50	E112M	7.8	7.4	7.2	2915	1.34	88.1	88.1	85.8	0.88	0.84	0.75	225	700	275	0.044
5.50	7.50	E132M	10.6	10.1	9.7	2925	1.83	89.2	89.2	89.2	0.88	0.85	0.80	200	600	250	0.117
7.50	10.00	E132M	14.7	14.0	13.5	2920	2.50	90.1	90.1	90.1	0.86	0.84	0.78	250	650	300	0.117
9.30	12.50	E160L	18	17	16	2925	3.10	90.7	90.7	89.7	0.88	0.84	0.8	225	750	275	0.136
11.00	15.00	E160L	20	19	19	2925	3.66	91.2	91.2	91	0.9	0.86	0.82	225	700	275	0.170
15.00	20.00	E160L	28	27	26	2920	5.00	91.9	91.9	91.5	0.88	0.86	0.80	250	700	300	0.170
18.50	25.00	E160L	35	33	32	2920	6.17	92.4	92.4	92.4	0.88	0.85	0.8	275	700	350	0.383
22.00	30.00	E180L	41	39	38	2940	7.29	92.7	92.7	91.5	0.87	0.83	0.77	250	600	300	0.436
30.00	40.00	E200L	55	52	50	2945	9.92	93.3	93.3	92.4	0.89	0.86	0.82	180	700	225	0.440
37.00	50.00	E200L	68	65	62	2945	12.24	93.7	93.5	92.7	0.88	0.86	0.81	160	650	200	3.400
45.00	60.00	E225M	86	81	78	2960	14.81	94	94	93.5	0.85	0.8	0.78	200	700	250	6.650
55.00	75.00	E250M	96	92	88	2970	18.04	94.3	94.3	93	0.92	0.88	0.84	250	700	300	6.650
75.00	100.00	E280M	131	124	120	2975	24.55	94.7	94.5	93.2	0.92	0.88	0.84	200	650	250	6.650
90.00	120.00	E280M	156	149	143	2975	29.47	95	95	94	0.92	0.88	0.84	175	650	225	13.310
110.00	150.00	E315M	197	187	181	2980	35.95	95.2	95.2	93.8	0.89	0.87	0.81	250	750	300	10.029
132.00	180.00	E315M	234	222	214	2980	43.14	95.4	95.4	94.8	0.9	0.88	0.85	225	650	275	10.029
160.00	215.00	E315L	283	268	259	2977	52.35	95.6	95.6	95	0.9	0.88	0.86	200	700	250	12.333
180.00	240.00	E315L	318	302	291	2977	58.89	95.7	95.5	95	0.9	0.85	0.81	200	650	250	12.333
200.00	270.00	E315L	345	328	316	2980	65.37	95.8	95.8	95	0.92	0.9	0.87	200	700	250	12.333
225.00	300.00	E355LX	392	373	359	2980	73.54	95.8	94.8	93.3	0.91	0.88	0.84	160	650	225	19.617
250.00	335.00	E355LX	441	419	403	2980	81.71	95.8	95.5	94.5	0.9	0.88	0.84	150	650	225	19.617
275.00	370.00	E355LX	490	466	449	2980	89.88	95.8	95.5	94.5	0.89	0.86	0.82	175	650	225	27.700

FL = Full Load; FLC = Full Load Current; FLT = Full Load Torque
 SGT. T = Starting Torque; SGT. C = Starting Current

* Tolerances are applicable as per IEC 60034-1 : 2004
 Full load current indicated are given for respective voltage designs



PERFORMANCE DATA FOR APEX SERIES MOTOR
Efficiency Values Complying To IE3 Class Of IEC60034-30:2014

OUTPUT		FRAME	FULL LOAD CURRENT (AMP)			FL	FLT	EFFICIENCY			POWER FACTOR			D.D.L STARTING		POT %FLT	GD ² KGM ²
KW	HP		IN		FL (AMP)	RPM	Kg -m	FL	3/4L	1/2L	FL	3/4L	1/2L	STT %FLT	SCC %FLA		
			380 V	400 V	415V												

4 POLE : 1500 RPM

0.75	1.00	E80	1.9	1.8	1.7	1410	0.52	82.5	82.5	81.5	0.73	0.66	0.55	200	500	250	0.010
1.10	1.50	E90L	2.7	2.6	2.5	1430	0.75	84.1	84.1	83.5	0.7283	0.675	0.5246	200	600	250	0.022
1.50	2.00	E90L	3.7	3.5	3.4	1440	1.01	85.3	85.3	84	0.72	0.65	0.54	200	600	250	0.022
2.20	3.00	E100L	4.9	4.7	4.5	1450	1.48	86.7	86.7	86	0.78	0.70	0.60	180	600	230	0.047
3.70	5.00	E112M	8.2	7.7	7.5	1450	2.49	88.4	88.4	88.2	0.78	0.74	0.62	200	600	250	0.264
5.50	7.50	E132M	10.8	10.3	9.9	1465	3.66	89.6	89.6	89.6	0.86	0.80	0.75	200	650	250	0.264
7.50	10.00	E132M	15.2	14.4	13.9	1457	5.01	90.4	90.4	90	0.83	0.77	0.66	225	650	275	0.260
9.30	12.50	E160L	18	17	16	1470	6.16	91	91	90	0.87	0.84	0.74	175	700	225	0.448
11.00	15.00	E160L	22	21	20	1470	7.29	91.4	91.4	91	0.83	0.78	0.70	250	600	300	0.448
15.00	20.00	E160L	30	29	28	1465	9.97	92.1	92.1	91	0.82	0.75	0.65	200	650	250	0.480
18.50	25.00	E180L	36	34	33	1470	12.26	92.6	92.6	92	0.85	0.80	0.75	200	600	250	0.925
22.00	30.00	E180L	42	40	39	1470	14.58	93	93	92.4	0.85	0.80	0.75	225	600	275	0.925
30.00	40.00	E200L	58	55	53	1470	19.88	93.6	93.6	93	0.84	0.81	0.72	200	600	250	1.793
37.00	50.00	E225S	73	69	67	1470	24.52	93.9	93.9	93	0.82	0.75	0.72	200	600	250	2.700
45.00	60.00	E225M	81	77	74	1475	29.72	94.2	94.2	93.5	0.90	0.85	0.80	225	650	275	3.130
55.00	75.00	E250M	100	95	92	1480	36.20	94.6	94.6	94	0.88	0.84	0.80	225	600	275	6.282
75.00	100.00	E280M	132	125	121	1485	49.19	95	94.6	94	0.91	0.88	0.84	200	650	250	11.622
90.00	120.00	E280M	163	155	149	1488	58.91	95.2	95.2	94.6	0.88	0.84	0.80	200	650	250	11.622
110.00	150.00	E315M	193	183	176	1490	71.91	95.4	95.4	94.8	0.91	0.88	0.82	200	650	250	20.308
132.00	180.00	E315M	233	221	213	1490	86.29	95.6	95.6	94.8	0.90	0.86	0.80	180	650	225	20.310
160.00	215.00	E315L	279	265	255	1488	104.73	95.8	95.8	95	0.91	0.88	0.85	200	650	250	26.068
180.00	240.00	E315L	313	298	287	1488	117.82	95.9	95.9	95.2	0.91	0.88	0.85	225	700	275	24.970
200.00	270.00	E315L	344	327	315	1489	130.83	96	96	95.3	0.92	0.90	0.86	200	700	250	27.990
225.00	300.00	E355LX	396	376	362	1490	147.08	96	95.8	95.3	0.90	0.88	0.84	150	600	225	28.000
250.00	335.00	E355LX	440	418	403	1490	163.42	96	96	95.5	0.90	0.86	0.81	180	800	225	29.600
275.00	370.00	E355LX	473	449	433	1485	180.37	96	96	95.5	0.92	0.88	0.84	175	700	225	31.600

FL = Full Load; FLC = Full Load Current; FLT = Full Load Torque
 SGT. T = Starting Torque; SGT. C = Starting Current

* Tolerances are applicable as per IEC 60034-1 : 2004
 Full load current indicated are given for respective voltage designs



PERFORMANCE DATA FOR APEX SERIES MOTOR
Efficiency Values Complying To IE3 Class Of IEC60034-30:2014

OUTPUT		FRAME	FULL LOAD CURRENT (AMP)			FL	FLT	EFFICIENCY			POWER FACTOR			D.D.L STARTING		POT %FLT	GD ² KGM ²
KW	HP		IN		FL (AMP)	RPM	Kg -m	FL	3/4L	1/2L	FL	3/4L	1/2L	STT %FLT	SCC %FLA		
			380 V	400 V	415V												

6 POLE : 1000 RPM

0.75	1.00	E90L	2.2	2.1	2.0	940	0.78	78.9	78.9	78.8	0.65	0.56	0.48	175	500	225	0.022
1.10	1.50	E90L	3.0	2.8	2.7	935	1.15	81	80.2	78.4	0.69	0.60	0.47	180	500	230	0.030
1.50	2.00	E100L	3.9	3.7	3.6	945	1.55	82.5	82.5	81.25	0.70	0.60	0.50	200	500	250	0.131
2.20	3.00	E112M	5.7	5.4	5.2	960	2.23	84.3	84.3	84	0.70	0.66	0.56	200	550	250	0.108
3.70	5.00	E132M	7.9	7.5	7.3	965	3.73	86.5	86.5	86	0.82	0.78	0.66	175	550	225	0.282
5.50	7.50	E132M	12.7	12.0	11.6	965	5.55	88	88	86.5	0.75	0.70	0.60	175	550	225	0.330
7.50	10.00	E160L	15	14	14	975	7.49	89.1	89.1	88.5	0.84	0.76	0.64	225	600	275	0.498
11.00	15.00	E160L	23	22	21	975	10.99	90.3	90.3	90	0.80	0.75	0.65	200	600	250	0.640
15.00	20.00	E180L	32	30	29	975	14.98	91.2	91.2	91	0.78	0.71	0.58	225	600	250	1.160
18.50	25.00	E200L	36	35	33	975	18.48	91.7	91.7	90.8	0.84	0.80	0.72	200	600	250	1.690
22.00	30.00	E200L	43	41	40	975	21.98	92.2	92.2	91	0.84	0.80	0.70	200	550	250	2.040
30.00	40.00	E225M	58	55	53	980	29.82	92.9	92.9	91.5	0.85	0.81	0.73	200	600	250	3.700
37.00	50.00	E250M	70	67	64	980	36.77	93.3	93.3	92.3	0.86	0.82	0.78	200	600	250	7.510
45.00	60.00	E280M	87	83	80	988	44.36	93.7	93.7	93	0.84	0.80	0.74	200	650	250	14.124
55.00	75.00	E280M	106	100	97	990	54.11	94.1	94.1	93.8	0.84	0.80	0.74	200	600	250	14.124
75.00	100.00	E315M	140	133	128	990	73.79	94.6	94.6	94	0.86	0.82	0.74	160	600	200	24.200
90.00	120.00	E315M	168	159	153	990	88.55	94.9	94.9	94	0.86	0.82	0.74	225	600	275	24.272
110.00	150.00	E315L	200	190	183	985	108.77	95.1	95.1	94	0.88	0.84	0.78	175	600	225	29.851
132.00	180.00	E315L	239	227	219	990	129.87	95.4	95.4	95	0.88	0.84	0.78	175	600	225	29.851
160.00	240.00	E355LX	296	281	271	990	157.41	95.6	95.6	95	0.86	0.82	0.74	200	600	250	35.600
180.00	240.00	E355LX	328	312	301	985	177.99	95.7	95.5	95	0.87	0.85	0.78	150	600	200	45.594
200.00	270.00	E355LX	373	355	342	985	197.77	95.8	95.5	94.5	0.85	0.81	0.75	130	600	225	45.594
225.00	300.00	E355LX	410	390	376	990	221.36	95.8	95.8	94.8	0.87	0.85	0.78	175	600	225	49.358
250.00	335.00	E355LX	449	427	411	990	245.96	95.8	95.8	94.8	0.88	0.87	0.80	175	600	225	49.358

FL = Full Load; FLC = Full Load Current; FLT = Full Load Torque
 SGT. T = Starting Torque; SGT. C = Starting Current

* Tolerances are applicable as per IEC 60034-1 : 2004
 Full load current indicated are given for respective voltage designs

WIDE RANGE OF APPLICATIONS ACROSS INDUSTRIES

Apex series LV AC flame proof motors are designed to work in different hazardous areas ensuring the high safety and with premium efficiency.



CG Ex'e' and Ex'n' Motors

Range	
Output	0.18kW to 325 kW
Frames	ND80 to ND355
Poles	2,4,6

Specification			
	Standard Product		Option
Frame sizes	ND80 to ND355		-
Enclosure	IP55		IP66
Zone	2		
Gas group	IIA IIB IIC		
Mounting	B3		Other per request
Voltage	Upto 3 kW	415V λ	other on request
	Above 3kW	415V Δ	
Frequency	50Hz		60HZ*
Cooling	IC411		
Insulation	Class F		Class H
Ambient Temperature	-20°C to 45°C		Standard output at different Ambient
			45°C 50°C 55°C 60°C
			100% 92% 85% 78%
Altitude	<1000		
Approvals	PESO		

*For more details on full specifications please contact CG sales

Dimension drawing E80 - E132 foot mounted Flame proof Induction motors

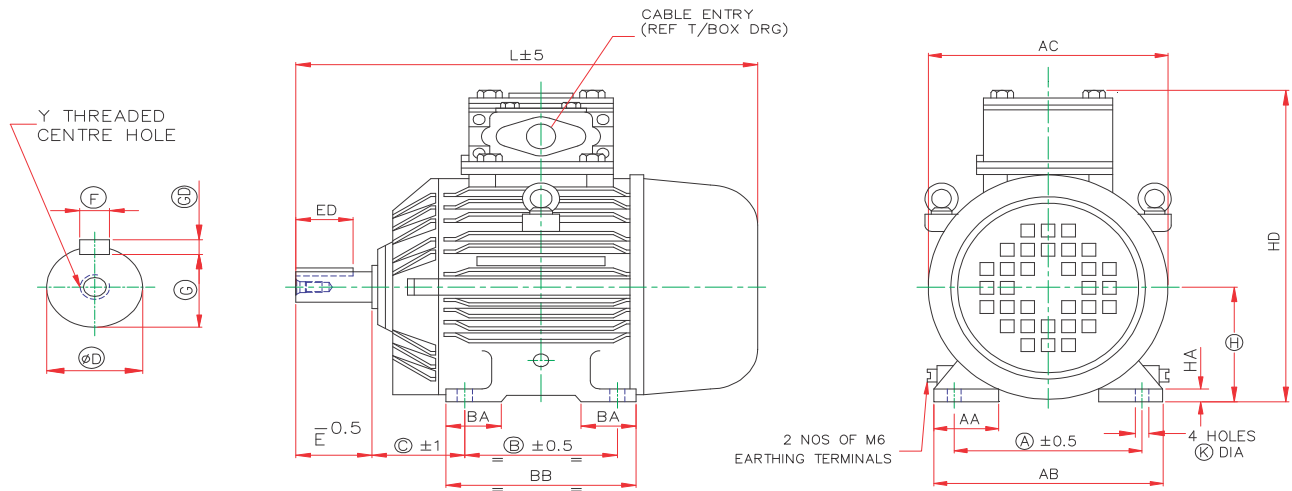

Frame	A	B	C	H	AA	AB	BA	BB	K	D	E	ED	F	GD	G	Y	AD	AC	L	HD	HA
E80	125	100	50	80.0/ 79.7	28	158	25	124	10.0/ 10.3	19.009/ 18.996	40	27	6.00/ 5.97	6.0/ 5.97	15.5/ 15.3	M6X16	--	165	274	268	11

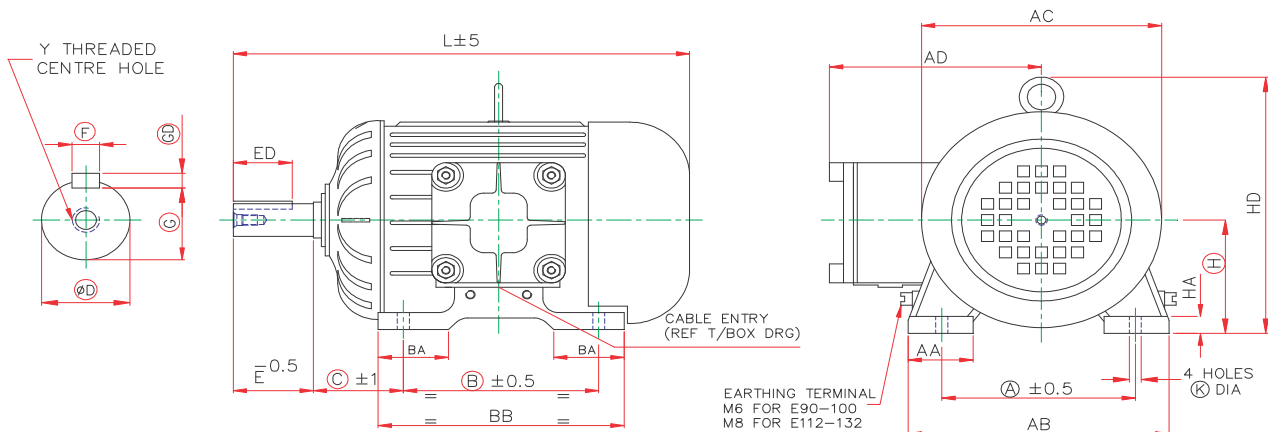

RINGED DIMENSIONS ARE AS PER IEC:60072-1
ALL DIMENSIONS ARE IN mm

Frame	A	B	C	H	AA	AB	BA	BB	K	D	E	ED	F	GD	G	Y	AD	AC	L	HD	HA
E90L	140	125	56	90.0/ 89.7	35	168	45	152	10.0/ 10.5	24.009/ 23.996	50	36	8.00/ 7.97	7.0/ 6.9	20.0/ 19.8	M8X19	240	210	375	240	13
E100L	160	140	63	100.0/ 99.7	38	198	51	168	12.0/ 12.5	28.009/ 27.996	60	44	8.00/ 7.97	7.0/ 6.9	24.0/ 23.8	M10X22	255	240	380	220	13
E112M	190	140	70	112.0/ 111.7	38	228	57	171	12.0/ 12.5	28.009/ 27.996	60	44	8.00/ 7.97	7.0/ 6.9	24.0/ 23.8	M10X22	270	270	405	245	14
E132M	216	178	89	132.0/ 131.7	41	254	64	216	12.0/ 12.5	38.018/ 38.002	80	60	10.0/ 9.96	8.0/ 7.9	33.0/ 32.8	M12X28	285	320	500	350	16

Dimension drawing E160 - E315, 2 Pole foot mounted Flame proof Induction motors

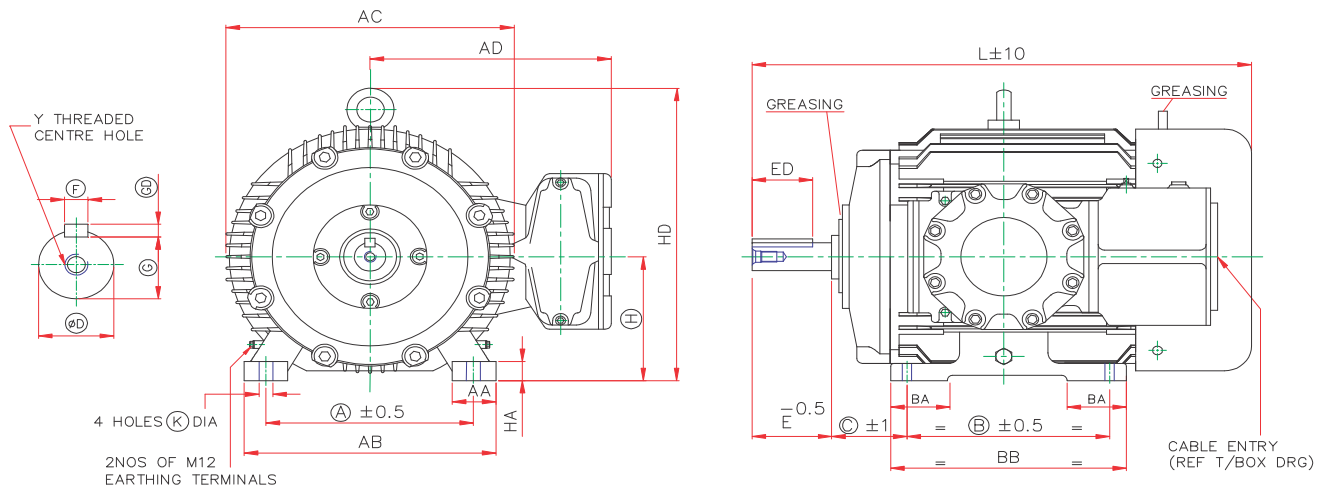

RINGED DIMENSIONS ARE AS PER IEC:60072-1
ALL DIMENSIONS ARE IN mm

Frame	A	B	C	H	AA	AB	BA	BB	K	D	E	ED	F	GD	G	Y	AD	AC	L	HD	HA
E160L	254	254	108	160.0/ 159.5	54	298	101	298	15.0/ 15.5	42.018/ 42.002	110	80	12.00/ 11.957	8.0/ 7.9	37.0/ 36.8	M16X32	345	320	655	376	22
E180L	279	279	121	180.0/ 179.5	60	337	107	323	15.0/ 15.5	48.018/ 48.002	110	80	14.00/ 13.957	9.0/ 8.9	42.5/ 42.3	M16X32	360	372	725	418	22
E200L	318	305	133	200.0/ 199.5	65	381	105	356	19.0/ 19.5	55.030/ 55.011	110	80	16.00/ 15.957	10.0/ 9.9	49.0/ 48.8	M20X40	380	455	815	495	25
E225S	356	286	149	225.0/ 224.5	70	425	114	349	19.0/ 19.5	55.030/ 55.011	110	80	16.00/ 15.957	10.0/ 9.9	49.0/ 48.8	M20X40	410	490	802	525	25
E225M	356	311	149	225.0/ 224.5	70	425	110	375	19.0/ 19.5	55.030/ 55.011	110	80	16.00/ 15.957	10.0/ 9.9	49.0/ 48.8	M20X40	410	490	827	525	25
E250M	406	349	168	250.0/ 249.5	90	483	157	419	24.0/ 24.5	60.030/ 60.011	140	110	18.00/ 17.957	11.0/ 10.9	53.0/ 52.8	M20X40	440	560	977	620	32
E280M	457	419	190	280.0/ 279.0	95	540	153	489	24.0/ 24.5	65.030/ 65.011	140	110	18.00/ 17.957	11.0/ 10.9	58.0/ 57.8	M20X40	485	620	1095	660	38
E315M	508	457	216	315.0/ 314.0	100	597	150	533	28.0/ 28.5	65.030/ 65.011	140	110	18.00/ 17.957	11.0/ 10.9	58.0/ 57.8	M20X40	516	705	1190	775	38

* Some features may be different and may not be a part of standard product.

Dimension drawing E160 - E315, 4 Pole foot mounted Flame proof Induction motors

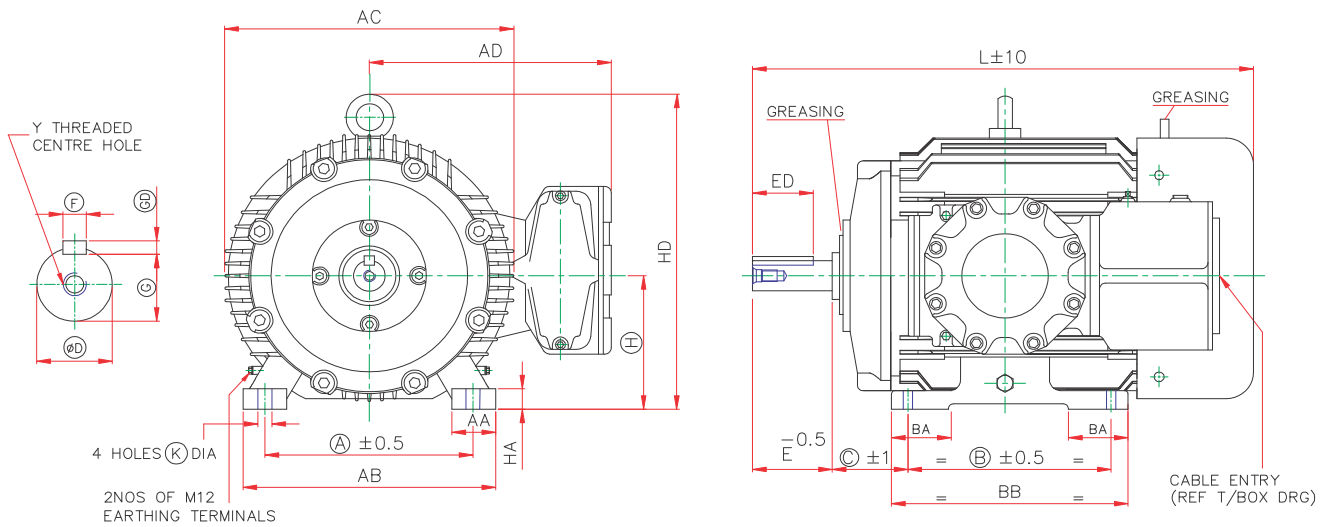

RINGED DIMENSIONS ARE AS PER IEC:60072-1
ALL DIMENSIONS ARE IN mm

Frame	A	B	C	H	AA	AB	BA	BB	K	D	E	ED	F	GD	G	Y	AD	AC	L	HD	HA
E160L	254	254	108	160.0/ 159.5	54	298	101	298	15.0/ 15.5	42.018/ 42.002	110	80	12.00/ 11.957	8.0/ 7.9	37.0/ 36.8	M16X32	345	320	655	376	22
E160LX	254	254	108	160.0/ 159.5	54	298	101	298	15.0/ 15.5	42.018/ 42.002	110	80	12.00/ 11.957	8.0/ 7.9	37.0/ 36.8	M16X32	345	320	745	376	22
E180L	279	279	121	180.0/ 179.5	60	337	107	323	15.0/ 15.5	48.018/ 48.002	110	80	14.00/ 13.957	9.0/ 8.9	42.5/ 42.3	M16X32	360	372	725	418	22
E200L	318	305	133	200.0/ 199.5	65	381	105	356	19.0/ 19.5	55.030/ 55.011	110	80	16.00/ 15.957	10.0/ 9.9	49.0/ 48.8	M20X40	380	455	815	495	25
E225S	356	286	149	225.0/ 224.5	70	425	114	349	19.0/ 19.5	60.030/ 60.011	140	110	18.00/ 17.957	11.0/ 10.9	53.0/ 52.8	M20X40	410	490	832	525	25
E225M	356	311	149	225.0/ 224.5	70	425	110	375	19.0/ 19.5	60.030/ 60.011	140	110	18.00/ 17.957	11.0/ 10.9	53.0/ 52.8	M20X40	410	490	857	525	25
E250M	406	349	168	250.0/ 249.5	90	483	157	419	24.0/ 24.5	65.030/ 65.011	140	110	18.00/ 17.957	11.0/ 10.9	58.0/ 57.8	M20X40	440	560	977	620	32
E280M	457	419	190	280.0/ 279.0	95	540	153	489	24.0/ 24.5	75.030/ 75.011	140	110	20.00/ 19.948	12.0/ 11.9	67.5/ 67.3	M20X40	485	620	1095	660	38
E315M	508	457	216	315.0/ 314.0	100	597	150	533	28.0/ 28.5	80.030/ 80.011	170	140	22.00/ 21.948	14.0/ 13.9	71.0/ 70.8	M20X40	516	705	1220	775	38

* Some features may be different and may not be a part of standard product.

OUTLINE DIMENSION DRAWING FOR 3 PHASE SQUIRREL CAGE TEFC FOOT MOUNTED FLAME PROOF TB ON TOP INDUCTION MOTORS (FRAME E315L & E355LX)

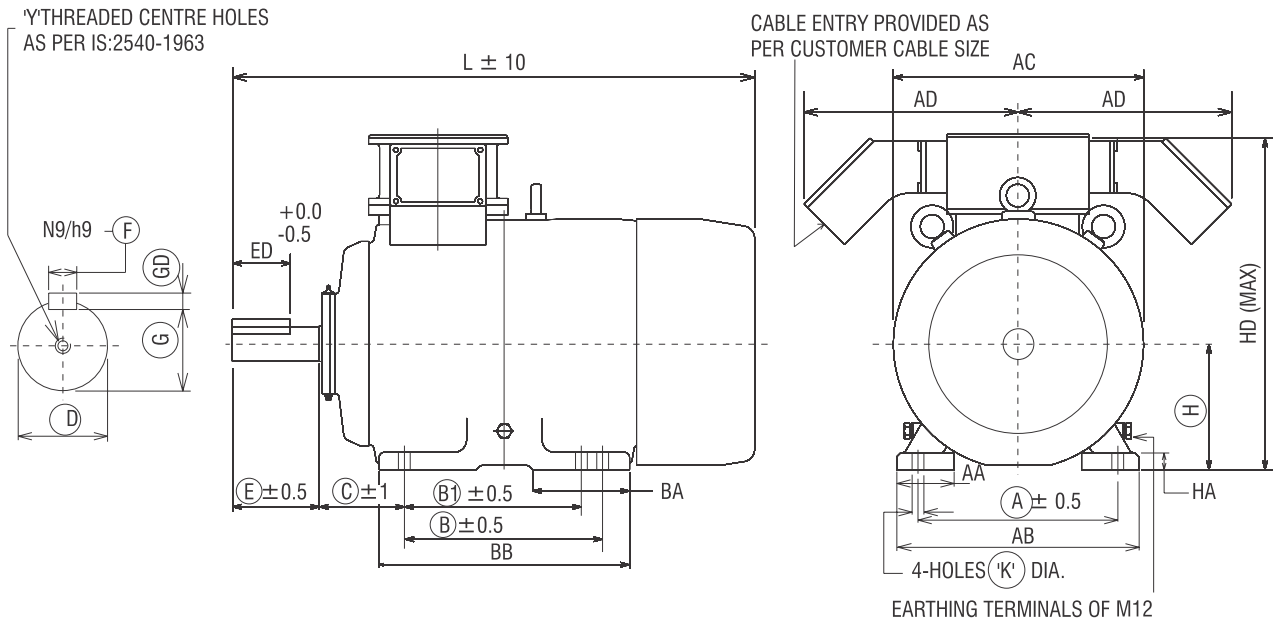

RINGED DIMENSIONS ARE AS PER IS:1231
ALL DIMENSIONS ARE IN mm

RINGED DIMENSIONS ARE AS PER IEC:60072-1
ALL DIMENSIONS ARE IN mm

Frame	A	B	B1	C	H	AA	AB	BA	BB	K	D	E	ED	F	GD	G	Y	AC	L	HD	HA	AD
2 POLE																						
E315L	508	508	-	216	315.0/ 314.0	100	610	125	590	28.5/ 28.0	70.030/ 70.011	140	110	20.0/ 19.948	12.0/ 11.91	62.5/ 62.3	M20X40	680	1350	875	38	480
E355LX	610	630	560	254	355.0/ 354.0	110	710	250	775	28.5/ 28.0	75.030/ 75.011	170	140	20.00/ 19.948	12.0/ 11.91	67.5/ 67.3	M24X50	720	1540	1025	40	600
2 POLE & UP																						
E315L	508	508	-	216	315.0/ 314.0	100	610	125	590	28.5/ 28.0	90.035/ 90.013	170	140	25.0/ 24.948	14.00/ 13.91	81.0/ 80.08	M24X50	680	1380	875	38	480
E355LX	610	630	560	254	355.0/ 354.0	110	710	290	775	28.5/ 28.0	100.035/ 100.013	210	160	28.00/ 27.948	16.00/ 15.89	90.0/ 89.8	M24X50	720	1580	1025	40	600

* Some features may be different and may not be a part of standard product.

Dimension Drawing E80 - E132 flange mounted Flame proof Induction motors

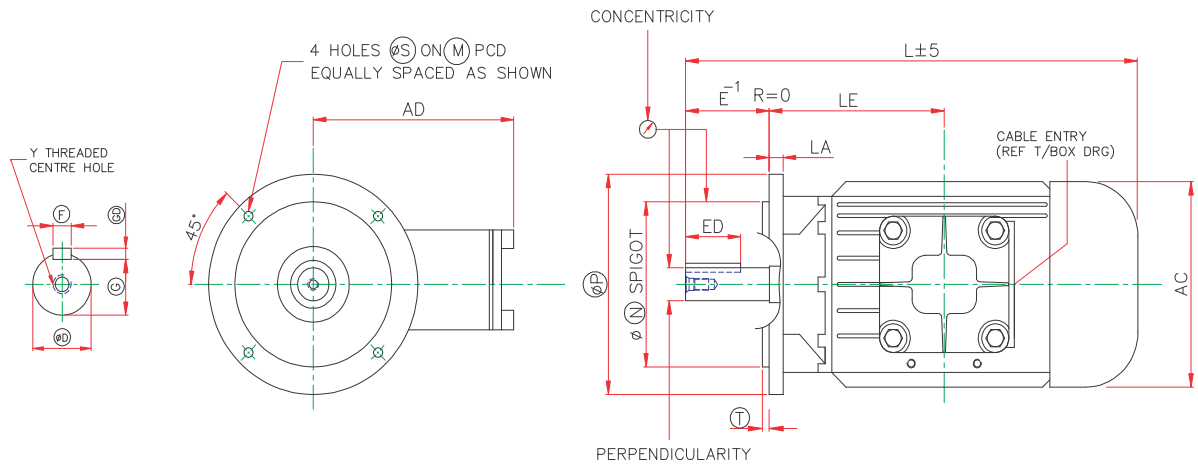

RINGED DIMENSIONS ARE AS PER IEC:60072-1
ALL DIMENSIONS ARE IN mm

Frame	D	E	ED	F	GD	G	Y	AD	AC	L	MTol	NTol	P	S	T	LA	LB	HB
E80	19.009/ 18.996	40	27	6.00/ 5.97	6.0/ 5.97	15.5/ 15.3	M6X16	205	165	274	165.3/ 164.7	130.014/ 129.989	200	12	3.5	10	100	--
E90L	24.009/ 23.996	50	36	8.00/ 7.96	7.0/ 6.9	20.0/ 19.8	M10X22	240	210	390	165.3/ 164.7	130.014/ 129.989	200	12	3.5	10	120	300
E100L	28.009/ 27.996	60	44	8.00/ 7.96	7.0/ 6.9	24.0/ 23.8	M10X22	255	240	380	215.3/ 214.7	180.014/ 179.989	250	15	4	11	135	330
E112M	28.009/ 27.996	60	44	8.00/ 7.96	7.0/ 6.9	24.0/ 23.8	M10X22	270	270	405	215.3/ 214.7	180.014/ 179.989	250	15	4	11	140	350
E132M	38.018/ 38.002	80	60	10.00/ 9.964	8.0/ 7.9	33.0/ 32.8	M12X28	290	320	500	265.3/ 264.7	230.016/ 229.987	300	15	4	13	180	440

* Some features may be different and may not be a part of standard product.

Dimension Drawing E160 - E315, 2 Pole flange mounted Flame proof Induction motors

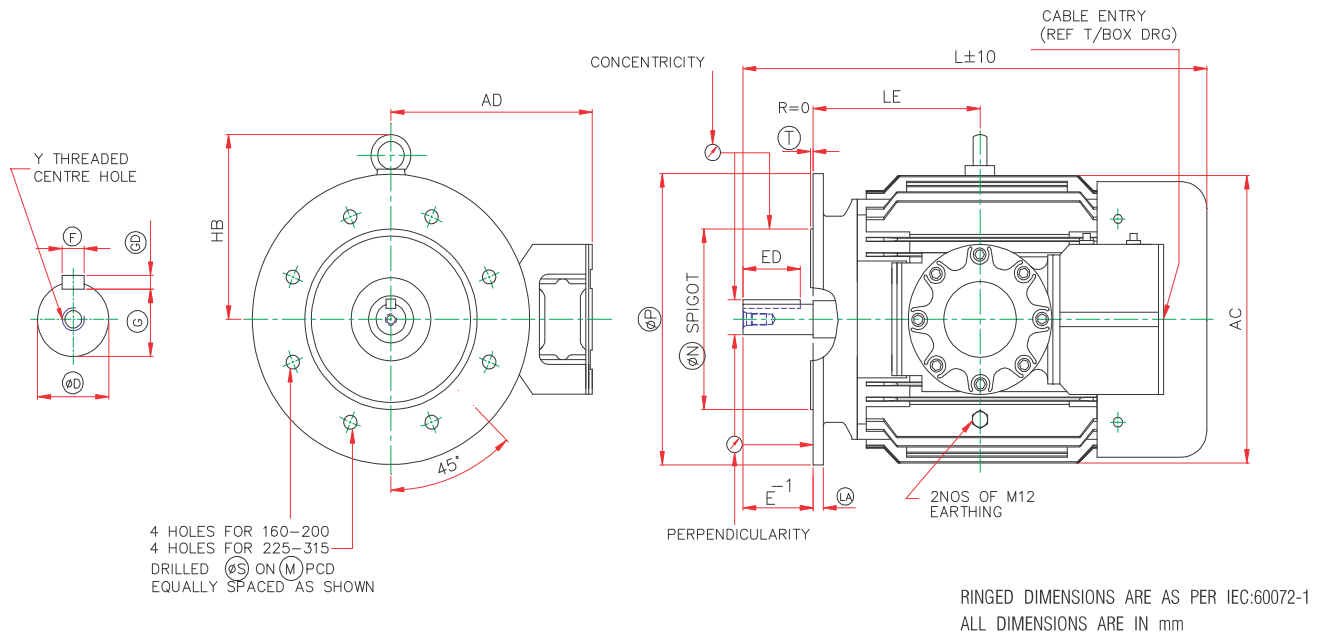

Frame	D	E	ED	F	GD	G	Y	AD	AC	L	MTol	NTol	P	S	T	LA	LB	HB
E160L	42.018/ 42.002	110	80	12.00/ 11.957	8.0/ 7.9	37.0/ 36.8	M16X32	345	320	655	300.5/ 299.5	250.016/ 249.987	350	19	5	18	235	440
E180L	48.018/ 48.002	110	80	14.00/ 13.957	9.0/ 8.9	42.5/ 42.3	M16X32	360	425	725	300.5/ 299.5	250.016/ 249.987	350	19	5	18	260	490
E200L	55.030/ 55.011	110	80	16.00/ 15.957	10.0/ 9.9	49.0/ 48.8	M20X40	380	435	790	350.5/ 349.5	300.018/ 299.982	400	19	5	18	285	560
E225S	55.030/ 55.011	110	80	16.00/ 15.957	10.0/ 9.9	49.0/ 48.8	M20X40	410	490	821	400.5/ 399.5	350.018/ 349.982	450	19	5	19	292	600
E225M	55.030/ 55.011	110	80	16.00/ 15.957	10.0/ 9.9	49.0/ 48.8	M20X40	410	490	827	400.5/ 399.5	350.018/ 349.982	450	19	5	19	305	600
E250M	60.030/ 60.011	140	110	18.00/ 17.957	11.0/ 10.9	53.0/ 52.8	M20X40	455	560	977	500.5/ 499.5	450.020/ 449.980	550	19	5	22	345	710
E280M	65.030/ 65.011	140	110	18.00/ 17.957	11.0/ 10.9	58.0/ 57.8	M20X40	485	620	1095	500.5/ 499.5	450.020/ 449.980	550	19	5	22	400	380
E315M	65.030/ 65.011	140	110	18.00/ 17.957	11.0/ 10.9	58.0/ 57.8	M20X40	516	705	1300	601.0/ 599.0	550.022/ 549.978	660	24	6	25	445	920
E315L	70.030/ 70.011	140	110	20.00/ 19.948	12.0/ 11.9	62.5/ 62.3	M20X40	480	620	1570	601.0/ 599.0	550.022/ 549.978	660	24	6	25	250	950

* Some features may be different and may not be a part of standard product.

Dimension Drawing E160 - E315, 4 Pole flange mounted Flame proof Induction motors

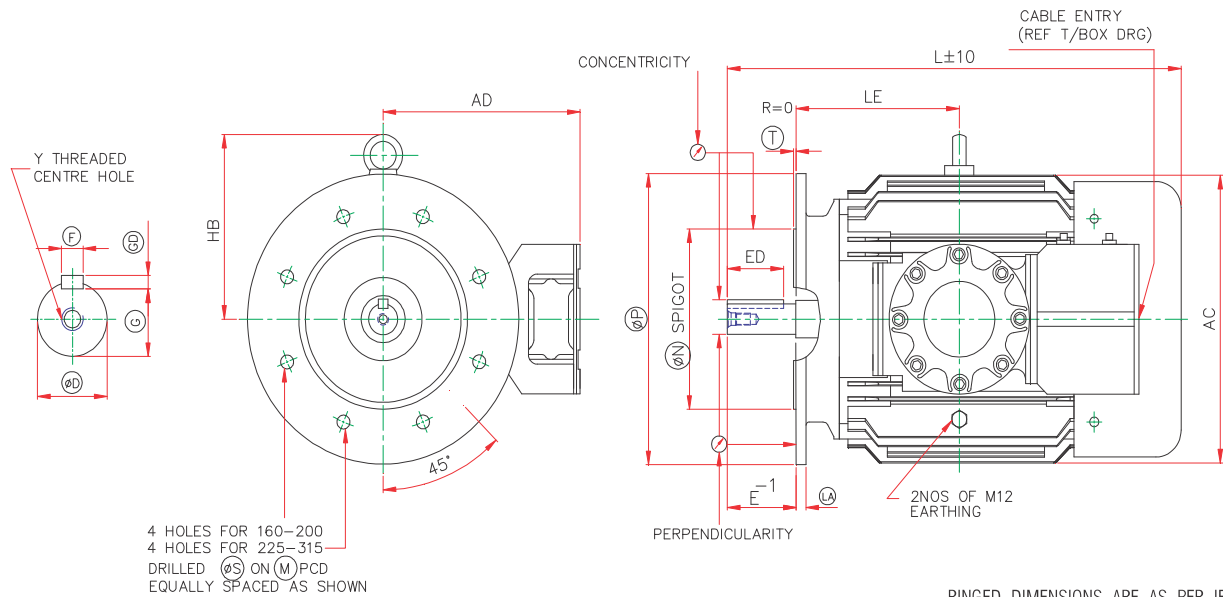

RINGED DIMENSIONS ARE AS PER IEC:60072-1
ALL DIMENSIONS ARE IN mm

Frame	D	E	ED	F	GD	G	Y	AD	AC	L	MTol	NTol	P	S	T	LA	LB	HB
E160L	42.018/ 42.002	110	80	12.00/ 11.957	8.0/ 7.9	37.0/ 36.8	M16X32	345	320	655	300.5/ 299.5	250.016/ 249.987	350	19	5	18	235	440
E180L	48.018/ 48.002	110	80	14.00/ 13.957	9.0/ 8.9	42.5/ 42.3	M16X32	360	425	725	300.5/ 299.5	250.016/ 249.987	350	19	5	18	260	490
E200L	55.030/ 55.011	110	80	16.00/ 15.957	10.0/ 9.9	49.0/ 48.8	M20X40	380	435	790	350.5/ 349.5	300.018/ 299.982	400	19	5	18	285	560
E225S	60.030/ 60.011	140	110	18.00/ 17.957	11.0/ 10.9	53.0/ 52.8	M20X40	410	490	857	400.5/ 399.5	350.018/ 349.982	450	19	5	19	292	600
E225M	60.030/ 60.011	140	110	18.00/ 17.957	11.0/ 10.9	53.0/ 52.8	M20X40	410	490	857	400.5/ 399.5	350.018/ 349.982	450	19	5	19	305	600
E250M	65.030/ 65.011	140	110	18.00/ 17.957	11.0/ 10.9	58.0/ 57.8	M20X40	455	560	1055	500.5/ 499.5	450.020/ 449.980	550	19	5	22	345	710
E280M	75.030/ 75.011	140	110	20.00/ 19.948	12.0/ 11.9	67.5/ 67.3	M20X40	485	620	1095	500.5/ 499.5	450.020/ 449.980	550	19	5	22	400	380
E315M	80.030/ 80.011	170	140	22.00/ 21.948	14.0/ 13.9	71.0/ 70.8	M20X40	516	705	1330	601.0/ 599.0	550.022/ 549.978	660	24	6	25	445	920
E315L	90.035/ 90.013	170	140	25.00/ 24.948	14.0/ 13.9	81.0/ 80.8	M20X40	480	620	1600	601.0/ 599.0	550.022/ 549.978	660	24	6	25	250	950

* Some features may be different and may not be a part of standard product.

OUTLINE DIMENSION DRAWING FOR 3 PHASE SQUIRREL CAGE TEFC FLANGE MOUNTED FLAME PROOF INDUCTION MOTOR. (FRAME : E315L)

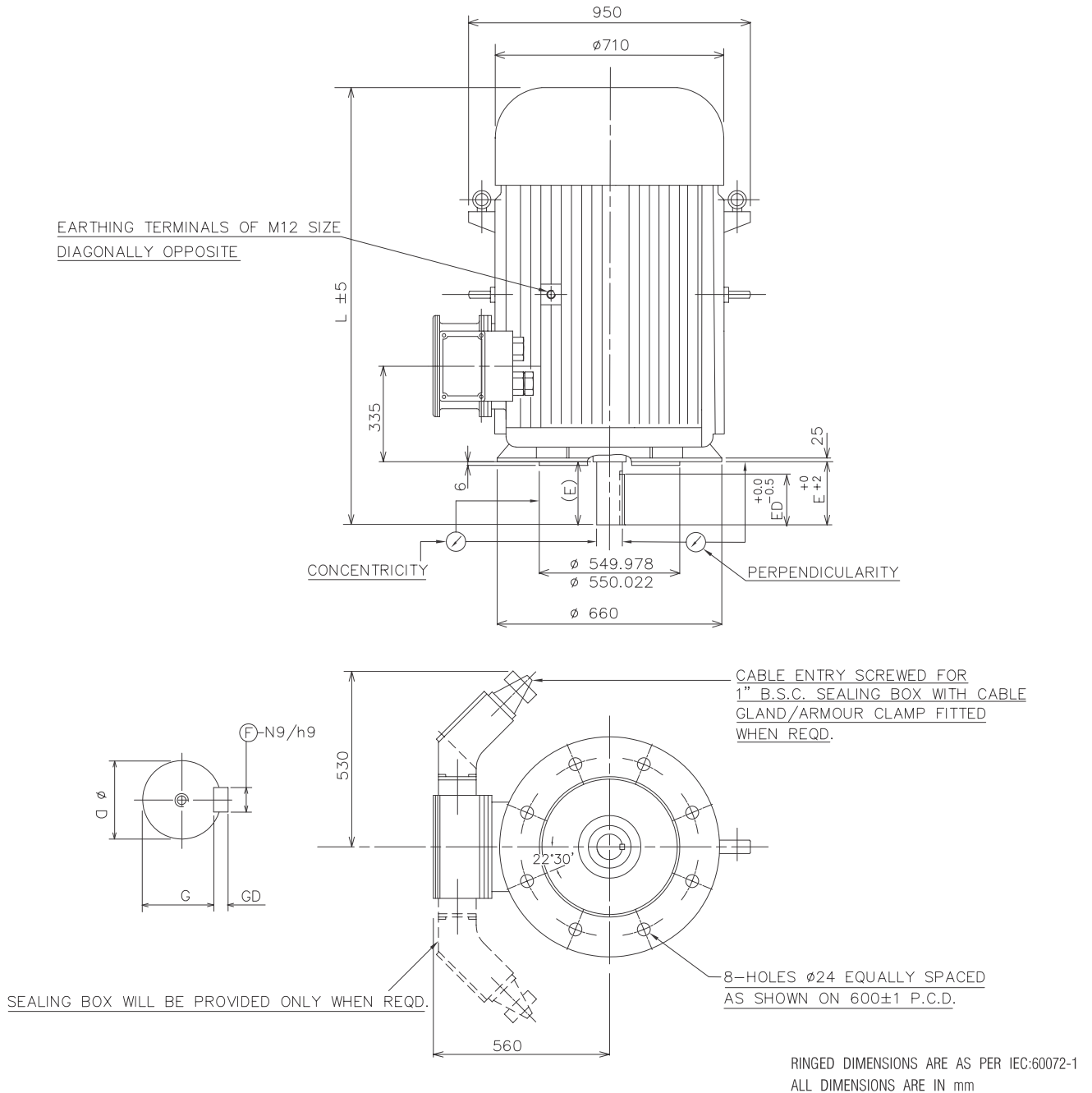

POLE	SHAFT AND KEY							
	D TOL.	E	ED	F TOL.	GD TOL.	G	Y	L
4P & UP	90.035/ 90.013	170	140	25.0/24.948	14.0/13.91	81.0/80.8	M24X50	1492
2	70.030/70.011	140	110	20.0/19.948	12.0/11.91	62.5/62.3	M20X40	1462

Bearing Details

Bearings			
Frame	Pole	Driving End	Non-Driving End
CAST IRON MOTORS			
E80	2,4,6	6304ZZ	6304ZZ
E90	2,4,6	6205ZZ	6205ZZ
E100	2,4,6	6206ZZ	6206ZZ
E112	2,4,6	6306ZZ	6306ZZ
E132	2,4,6	6308ZZ	6208ZZ
E160	2,4,6	6309-ZZ	6309-ZZ
E180	2,4,6	6310-ZZ	6310-ZZ
E200	2,4,6	6312-ZZ	6312-ZZ
E225	2,4,6	6313-ZZ	6313-ZZ
E250	2,4,6	6315-C3	6315-C3
E280	4,6	6318-C3	6318-C3
E280	2	6315-C4	6315-C4
E315	4,6	6319-C3	6319-C3
E315	2	6315-C4	6315-C4
E355LX-2P	-	6318-C3	6318-C3
E355LX-4P UP	-	6322	6322

NOTE: - Roller bearing for belt driven motors Frame 160 to 355 (other than 2 pole)
 Online greasing bearing for frame E160 to E225
 Insulated bearing for inverter duty flame proof motors can be provided (E200 to E355Lx),
 for more details on VFD compatible flame proof motors please contact CG sales

Noise Limits (IEC 60034-9) - 2007

Maximum A-weighted sound power level ,in dB ,at no-load
 (For single speed three-phase Squirrel cage induction motor IC411)

Shaft height.			
H mm	2 pole	4 pole	6 pole
90	78	66	63
100	82	70	64
112	83	72	70
132	85	75	73
160	81	76	72
180	82	78	76
200	83	79	78
225	84	82	80
250	85	83	82
280	88	86	84
315	90	89	87
355	92	90	88

Cable Details

FRAME	St. Cable entry/ Cable size	Max. Cable Entry / Cable Size
E80-E132	M20 x 1.5P - 1No. Cable Size: 1R x 3C x 6 mm ²	M25 x 1.5P - 1No. Cable Size: 1R x 3C x 16 mm ²
E160-E200	M25 x 1.5P - 2 Nos. Cable Size: 2R x 3C x 35 mm ²	M32 x 1.5P - 2 Nos. Cable Size: 2R x 3C x 70 mm ²
E225-E280	M40 x 1.5P - 2 Nos. Cable Size: 2R x 3C x 95 mm ²	M63 x 1.5P - 2 Nos. Cable Size: 2R x 3C x 225 mm ²
E315	M50 x 1.5P 2 Nos Cable Size: 2R x 3C x 185 mm	M63 x 1.5P 2 Nos. Cable Size: 2R x 3C x 240 mm
E355LX	M50 x 1.5P - 2 Nos Cable Size: 2R x 3C x 185 mm	M63 x 1.5P 2 Nos. Cable Size: 2R x 3C x 240 mm

MOUNTING ARRANGMENTS (IEC 60034-7)

HORIZONTAL		
FIGURE		
REF	B3	B5
FRAME	WITH FEET	WITHOUT FEET
SHAFT	HORIZONTAL	HORIZONTAL
MTNG	BASE OR RAILS	FLANGE TYPE D
FIGURE		
REF	B35	B14
FRAME	WITH FEET & FLANGE	WITHOUT FEET
SHAFT	HORIZONTAL	HORIZONTAL
MTNG	BASE OR FLANGE TYPE D	FLANGE TYPE C
FIGURE		
REF	B34	B6
FRAME	WITH FEET	WITH FEET
SHAFT	HORIZONTAL	HORIZONTAL
MTNG	BASE OR FLANGE TYPE C	WALL
FIGURE		
REF	B7	B8
FRAME	WITH FEET	WITH FEET
SHAFT	HORIZONTAL	HORIZONTAL
MTNG	WALL	CEILING

VERTICAL		
FIGURE		
REF	V1	V5
FRAME	WITHOUT FEET	WITH FEET
SHAFT	FACE VERT.DOWN	FACE VERT.DOWN
MTNG	FLANGE TYPE D	BASE OR RAILS
FIGURE		
REF	V15	V3
FRAME	WITH FEET	WITHOUT FEET
SHAFT	FACE VERT.DOWN	FACE VERT.UP
MTNG	WALL OR FLANGE TYPE D	FLANGE TYPE D
FIGURE		
REF	V36	V6
FRAME	WITH FEET	WITH FEET
SHAFT	FACE VERT.UP	FACE VERT.UP
MTNG	WALL OR FLANGE TYPE D	BASE OR RAILS
FIGURE		
REF	V18	V19
FRAME	WITHOUT FEET	WITHOUT FEET
SHAFT	FACE VERT.DOWN	FACE VERT.UP
MTNG	FLANGE TYPE C	FLANGE TYPE C

LV FLAME PROOF MOTORS

SHIPPING SPECIFICATIONS

SHIPPING SPECIFICATIONS

FOOT MOUNTING MOTORS					FLANGE MOUNTING MOTORS				
Frame	kg			VOL.	Frame	kg			VOL.
SIZE	NET WT	GR WT	L X B X H	CU.M.	SIZE	NET WT	GR WT	L X B X H	CU.M.
E80	23	27	345 X 220 X 335	0.025	E80	25	30	345 X 220 X 335	0.025
E90L	40	56	467 X 477 X 319	0.071	E90L	42	70	528 X 362 X 672	0.128
E100L	54	74	507 X 507 X 368	0.095	E100L	56	89	582 X 422 X 687	0.169
E112M	73	102	590 X 532 X 427	0.134	E112M	76	109	582 X 422 X 687	0.169
E132M	110	143	622 X 575 X 427	0.153	E132M	113	156	628 X 472 X 732	0.216
E160L	188	259	875 X 705 X 427	0.36	E160L	215	333	960 X 815 X 815	0.64
E180L	256	362	1025 X 825 X 700	0.59	E180L	260	378	960 X 815 X 815	0.64
E200L	263	369	1025 X 825 X 700	0.59	E200L	300	442	1065 X 885 X 840	0.79
E225S	330	382	1150 X 845 X 710	0.69	E225S	365	510	1065 X 885 X 840	0.79
E225M	400	449	1150 X 845 X 710	0.69	E225M	435	577	1065 X 885 X 840	0.79
E250M	680	818	1300 X 915 X 745	0.89	E250M	705	935	990 X 900 X 1245	1.11
E280M	966	1180	1500 X 1065 X 850	1.36	E280M	1000	1270	1070 X 1070 X 1430	1.64
E315M	1136	1389	1600 X 1170 X 925	1.73	E315M	1180	1508	1280 X 1210 X 1545	2.39
E315L	1752	2105	1830 X 1270 X 1156	2.69	E315L	1800	2214	1850 X 1450 X 1275	3.42
E355LX	2150	2500	2565 X 1245 X 1120	3.58	—	—	—	—	—

*Shipping details may vary at the time of execution of order.

SAMPLE NAMEPLATES DGMS/PESO/ERTL

		FLAMEPROOF ENCLOSURE Ex "d"			
IS/IEC 60079-1		3 PH INDUCTION MOTOR		CM/L-0870053	
MADE BY CROMPTON GREAVES LTD					
kw(HP)	RPM	M/C No.			
VOLT.	A	FRAME			
REF.	AMB °C	EFF(FL) % Hz			
INS CL/TEMP RISE LIMIT	PF:	DUTY IP			
BRGS DE/NDE		GROUP: II A IIB T	TEMP CL.		
ERTL(E)/TES/C184/		DGMS APP NO.			
CCE No:		CERT.No.	/EHQ		
TAG NO.		Wt	IEC 60034-1	EAB411/883580	

CAUTION: ALUMINIUM DIE-CAST ROTOR. NOT TO BE DISMANTLED ASSEMBLED OR KEPT EXPOSED IN EXPLOSIVE GAS ATMOSPHERE.

Atex

		FLAMEPROOF ENCLOSURE			
3 PH ELECTRIC MOTOR		MADE BY CROMPTON GREAVES LTD			
MACHINE No.	RPM	EFF(FL)	% IP		
kw(HP)	A	DUTY.	INS.CL.		
VOLT.	AMB °C	CONN DIAG.	HZ		
REF.			RELUB. HRS.		
BRGS:DE/NDE			CERT NO.(ATEX) :		
** II 2 G Ex d IIB T*	Gb(-20°C ≤ Ta ≤ *°C)				
MFG/MM/YY	AMB. TEMP(T amb)	-20°C ≤ T amb ≤ + * °C			
TAG NO.					
WARNING-DO NOT OPEN WHEN AN EXPLOSIVE ATMOSPHERE IS PRESENT		EN:60079-0 & EN:60079-1			

		3 PH INDUCTION MOTOR		IS/IEC 60079-1	
CROMPTON GREAVES LTD		Ex "d"			
MACHINE No	FRAME	CM/L-0870053			
kw(HP)	EFF	Hz			
VOLT	CON DIAG	IP			
REF	GROUP	DUTY			
TH CL/ TEMP RISE	MTG	T TEMP CL			
BRGS DE/NDE	GREASE	RELUB HRS			
ERTL(E)/TES/C184/	DGMS APP NO	GREASE QTY g			
CCE No	CERT No	/EHQ			
TAG NO. ***	Wt	kg IEC 60034-1			
		WB*			

QA8689/8897R0

		FLAMEPROOF ENCLOSURE			
3 PH ELECTRIC MOTOR		MADE BY CROMPTON GREAVES			
MACHINE No.	RPM	EFF(FL)	% IP		
kw(HP)	A	DUTY.	INS.CL.		
VOLT.	AMB °C	CONN DIAG.	HZ		
REF.			RELUB. HRS.		
BRGS:DE/NDE			CERT NO.(ATEX) :		
** II 2 G Ex d IIB T*	Gb(-20°C ≤ Ta ≤ *°C)		CERT NO.(IECEx) :		
MFG/MM/YY	AMB. TEMP(T amb)	-20°C ≤ T amb ≤ + * °C			
TAG NO.					
WARNING-DO NOT OPEN WHEN AN EXPLOSIVE ATMOSPHERE IS PRESENT		EN/IEC:60079-0 & EN/IEC:60079-1			

Flameproof Motors with Brake

The installation of electric motors where flammable products are continuously handled, processed or storage must comply with the most demanding safety standards in order to guarantee life protection, machines and environment. Following to highest safety standards, CG Flame proof motors integrate the high performance of the brakes. An effective solution for equipment where fast safety stops are required, as well as precise positioning with safety in hazardous areas such as Zone 1 and Zone 2.

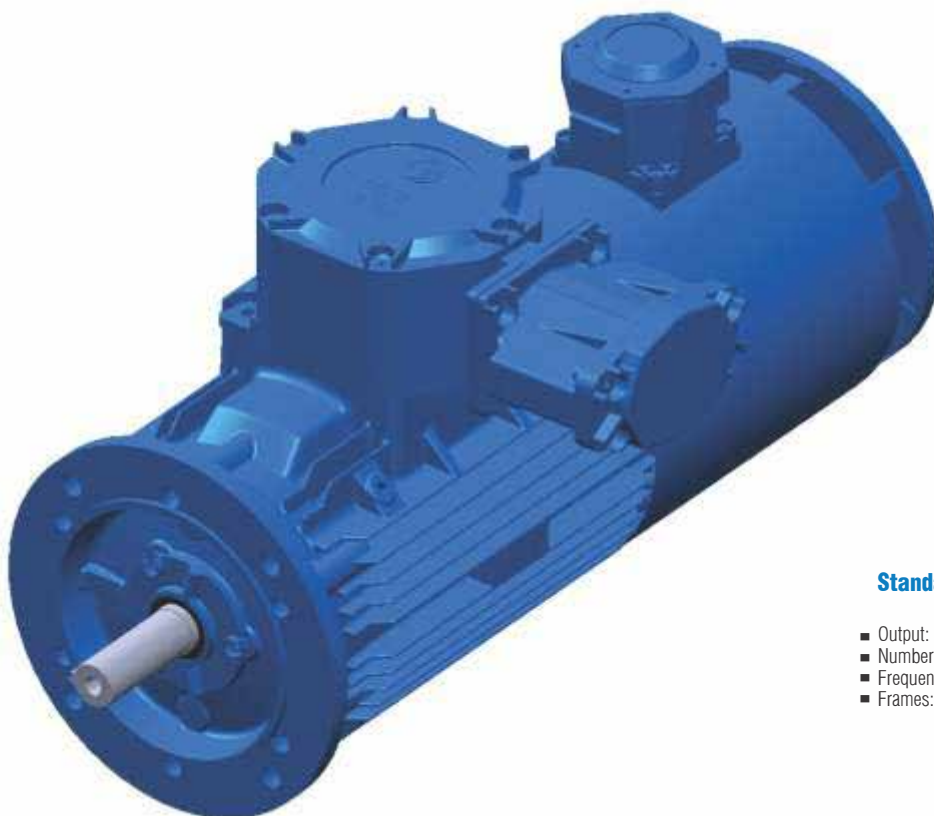

Standard Features

- Output: 0,37 up to 37 kW
- Number of Poles: 2,4,6 and 8
- Frequency: 50 Hz
- Frames: E90 to E160

Applications

Pumps, compressors, fans, blowers, conveyors and other severe duty applications in explosive atmospheres classified as Zones 1 and 2, gas groups IIA or IIB or IIC

Features	Benefits
High performance braking system	Ensures quick and safe stops and accurate load positioning and requires low maintenance
Modern flame retention system with robust frame, end shields and T-box	Avoid flame propagation from inside the motor to the external side, guaranteeing safety life protection, machines and environment
Additional nameplate	Easy identification of the motors in the factory and traceability
Painting Plan for Severe Environments	Special for industrial severe environments, sheltered or not, which may contain
Protection	Motor suitable to operate in hazardous locations classified as Zones 1 and 2

Minimum efficiency values defined in IEC 60034-30:2008 & Annual energy savings

kW	IE1			IE2			IE3			IE2 Vs IE1 saving in kWh			IE3 Vs IE2 Saving in kWh			IE3 Vs IE1 Saving in kWh		
	2	4	6	2	4	6	2	4	6	2	4	6	2	4	6	2	4	6
0.75	72.1	72.1	70	77.4	79.6	75.9	80.7	82.5	78.9	624	859	730	347	290	329	971	1149	1059
1.1	75	75	72.9	79.6	81.4	78.1	82.7	84.1	81	742	1010	880	454	380	442	1196	1390	1322
1.5	77.2	77.2	75.2	81.3	82.8	79.8	84.2	85.3	82.5	858	1151	1007	557	465	539	1415	1616	1546
2.2	79.7	79.7	77.7	83.2	84.3	81.8	85.9	86.7	84.3	1017	1319	1243	728	633	699	1745	1952	1942
3	81.5	81.5	79.7	84.6	85.5	83.3	87.1	87.7	85.6	1182	1509	1425	892	771	848	2073	2280	2273
4	83.1	83.1	81.4	85.8	86.6	84.6	88.1	88.6	86.8	1327	1704	1628	1066	913	1050	2393	2618	2678
5.5	84.7	84.7	83.1	87	87.7	86	89.2	89.6	88	1504	1946	1955	1366	1165	1273	2870	3111	3228
11	87.6	87.6	86.4	89.4	89.8	88.7	91.2	91.4	90.3	2215	2695	2892	2127	1878	1925	4342	4573	4817
15	88.7	88.7	87.7	90.3	90.6	89.7	91.9	92.1	91.2	2625	3107	3341	2533	2362	2409	5158	5469	5750
18.5	89.3	89.3	88.6	90.9	91.2	90.4	92.4	92.6	91.7	3194	3781	3642	2894	2687	2541	6089	6467	6184
22	89.9	89.9	89.2	91.3	91.6	90.9	92.7	93	92.2	3287	3979	4041	3188	3167	2989	6475	7146	7030
30	90.7	90.7	90.2	92	92.3	91.7	93.3	93.6	92.9	4094	5023	4766	3980	3954	3702	8074	8977	8468
37	91.2	91.2	90.8	92.5	92.7	92.2	93.7	93.9	93.3	4995	5751	5420	4488	4468	4145	9482	10219	9565
45	91.7	91.7	91.4	92.9	93.1	92.7	94	94.2	93.7	5553	6464	6048	4966	4944	4538	10518	11409	10587
55	92.1	92.1	91.9	93.2	93.5	93.1	94.3	94.6	94.1	6174	7833	6757	6030	5992	5500	12204	13825	12257
75	92.7	92.7	92.6	93.8	94	93.7	94.7	95	94.6	8311	9802	8329	6657	7357	6671	14968	17159	15000
90	93	93	92.9	94.1	94.2	94	95	95.2	94.9	9910	10799	9931	7937	8791	7954	17847	19591	17885
110	93.3	93.3	93.3	94.3	94.5	94.3	95.2	95.4	95.1	10952	13115	10952	9660	9620	8596	20613	22735	19548
132	93.5	93.5	93.5	94.6	94.7	94.6	95.4	95.6	95.4	14380	15671	14380	10250	11495	10250	24630	27166	24630
160	93.8	93.8	93.8	94.8	94.9	94.8	95.6	95.8	95.6	15762	17320	15762	12372	13875	12372	28134	31195	28134
200	94	94	94	95	95.1	95	95.8	96	95.8	19619	21558	19619	15401	17271	15401	35020	38830	35020
225	94	94	94	95	95.1	95	95.8	96	95.8	22072	24253	22072	17326	19430	17326	39397	43684	39397
275	94	94	94	95	95.1	95	95.8	96	95.8	26976	29643	26976	21176	23748	21176	48152	53391	48152
300	94	94	94	95	95.1	95	95.8	96	95.8	29429	32338	29429	23101	25907	23101	52530	58245	52530
315	94	94	94	95	95.1	95	95.8	96	95.8	30900	33955	30900	24256	27202	24256	55156	61157	55156
375	94	94	94	95	95.1	95	95.8	96	95.8	36786	40422	36786	28876	32384	28876	65662	72806	65662

* Annual energy savings are calculated for 8760 hrs/ annum

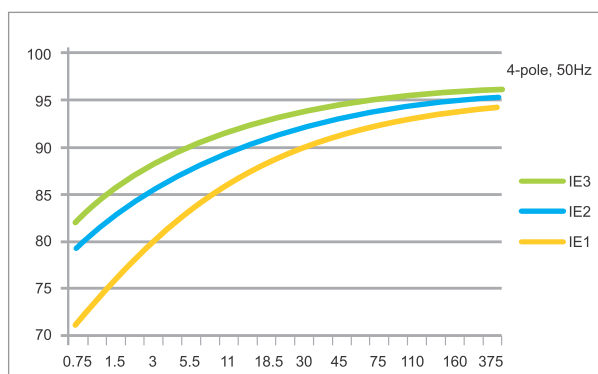

Efficiency class comparison

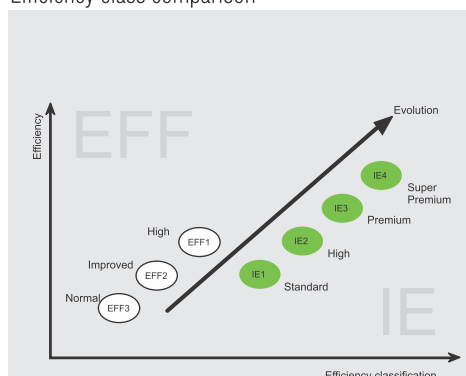

Initial cost Vs Lifetime cost of induction motor

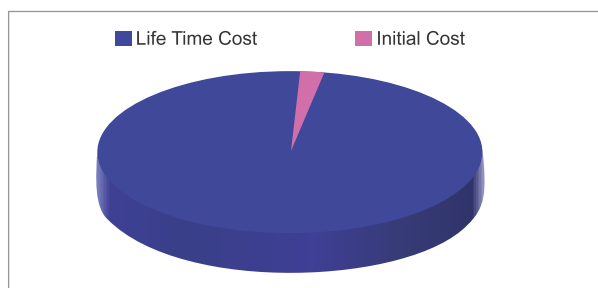

Example:

Energy savings by replacing 11kW 2 pole IE1 motor to IE3 motor:

$$\begin{aligned}
 \text{Annual Savings} &= \text{No. of units energy saved} \times R \\
 &= 4342 \times 5 \text{ ₹} \\
 &= 21710 \text{ ₹}
 \end{aligned}$$

*R= Energy Tariff in local currency

$$\text{Payback (months)} = \frac{\text{Cost of energy efficient motor} - \text{cost of standard motor}}{\text{Annual energy savings}} \times 12$$

Eco Friendly Packaging Scheme



Aware & concerned about the environmental issues, CG has developed special packing Case in fabrication.

With this initiative more than
7200 Trees are being Saved
Every Year

Packaging Pattern Patented By Crompton Greaves
App No : 415/MUM/2011 A

North

Delhi : 3rd Floor, Express Building, 9 - 10 Bahadur Shah Jafar Marg,
Near ITO Crossing, New Delhi - 110 002

Phone : 011 - 23460700

Lucknow : 0522 - 4935765

Jalandhar : 0181 - 3051395

Jaipur : 0141 - 3018800/ 29

South

Chennai: 3 - A, MGR Salai (K. H. Road),

Nungambakham, Chennai - 600 034

Phone : 044 - 4224 7525

Bengaluru : 080 - 41391931, 41391908 / 909

Secunderabad : 040 - 40002300, 40002347

Cochin : 0484 - 2805861/ 62

CG Drives & Automation

Mörsaregatan 12

SE -250 24 Helsingborg, Sweden

Phone : +46 42 169900

Fax : +46 42 169949

CG Electric Systems Hungary Zrt.

Rotating Machine Business Unit ,

H- 1095 Budapest,

Mariassy Utca 7.

Phone : + 36 14836600

Fax : + 36 14836862

CG Sales Network France S.A

Service Commercial -Paris ,

41, Boulevard Vauban,

78 280 GUYANCOURT,

France.

Phone: (+33) 01 34 52 10 80

Fax : (+33) 01 34 52 27 30

PT. CG Power System, Indonesia

Global Sales Network

Alamanda Buildings, 18th Floor

Jl TB simatupang kav 23-14,

Jakarta 12430.

Phone: +622 129660055

Fax : +622 129660054

West

Mumbai : Kanjur Marg (E), Mumbai - 400 042

Phone : 022 - 6755 8632, 33, 36 & 6755 8000

Ahmadabad : 079 - 4001200, 40012201

Indore : 0731 - 2498269, 2498276

Nagpur : 0712 - 2531271, 2560870 / 71

Pune : 020 - 25534675 / 77

Raipur : 0771 - 4022215

CG International division

Jagruti Buildings, 2nd Floor,

Kanjurmarg (E)

Mumbai, India.

Phone: +91 22 67558944

CG Drives & Automation

Goethestraße 6

D- 38855 Wernigerode. Germany

Phone : + 49 (0) 3943-92050

Fax : + 49 (0) 3943-92055

CG Sales Network

Americas Inc

3625 NW 82nd

AVE; Ste 203, Miami, Florida.

33166- USA

CG Sales Network UAE Ltd.

P. O. Box 5730

Sharjah,

UNITED ARAB EMIRATES

Phone: + 971 6 574 03 13

Fax : + 971 6 574 01 31

CG Drives & Automation

Rm 912 , Silver Centre

1388 North Shanxi Road

Putuo District, Shanghai.

China 200060

Phone: +86 21 6149 8346

Fax : +86 21 6440 1637

East

Kolkata: 50, Chowringhee Road, Kolkata - 700 071

Phone : 033 - 22829681 / 85

Bhubaneswar : 0674 - 2531128 / 2531429

Patna : 0612 - 32615994

Guwahati : 8811094991

CG Power Solutions UK Limited,

Concepts House,3

Watchgate , Newby Road

Industrial Estate , Hazel

Grove , SK7 5DB , United Kingdom

T: + 44845 634 11 33

CG Drives & Automation

Polakkers 5, 55331 NX Bladel

The Netherlands.

Phone: +31 (0) 497 389 222

Fax : +31 (0) 497 389 275

CG Sales Network

Americas Inc

6349, AVANTHA Drive Inc

Washington , Missouri

63090, USA

Industrial System-- SEA Malaysia

B-1-21, Block B

Jalan Sg. Jernih, 8/1,

Pusat Perniagaan, Seksyen-8

Petaling Jaya- 46050, Kuala Lumpur, Malaysia

Phone: +603 795 44 766

Fax : +603 795 42 766

CG India

Jagruti Buildings, 2nd Floor,

Kanjurmarg (E)

Mumbai, India.

Phone: +91 22 67558944



Ref : CG/LVRM/2016/FLP IE2/IE3 /Feb 16.

Due to continuous product improvements and its incorporation, CG reserves the right to change the design ,technical specifications and dimensions without prior notice.

For more information :

Visit us at : www.cgglobal.com