

Bonfiglioli Riduttori

TA series

Riduttori pendolari

Shaft mounted gearboxes

Aufsteckgetrieben

Réducteurs pendulaires





INFORMAZIONI GENERALI
GENERAL INFORMATION
ALLGEMEINE INFORMATIONEN
INFORMATIONS GENERALES

Paragrafo
 Chapter
 Abschnitt
 Paragraphe



	Descrizione	Description	Beschreibung	Description	
1	Coppia	<i>Torque</i>	Abtriebsmoment	<i>Couple</i>	2
2	Potenza	<i>Power</i>	Leistung	<i>Puissance</i>	2
3	Velocità angolare	<i>Angular velocity</i>	Drehzahl	<i>Vitesse angulaire</i>	2
4	Fattore di servizio	<i>Service factor</i>	Betriebsfaktor	<i>Facteur de service</i>	3
5	Manutenzione	<i>Maintenance</i>	Wartung	<i>Entretien</i>	4
6	Selezione	<i>Selection</i>	Antriebsauswahl	<i>Sélection</i>	4
7	Verifiche	<i>Verification</i>	Prüfungen	<i>Vérifications</i>	5
8	Installazione	<i>Installation</i>	Installation	<i>Installation</i>	5
9	Stoccaggio	<i>Storage</i>	Lagerung	<i>Stockage</i>	7
10	Condizioni di fornitura	<i>Conditions of supply</i>	Lieferbedingungen	<i>Conditions de livraison</i>	7
11	Specifiche della vernice	<i>Paint specifications</i>	Angaben zu den Anrichstoffe	<i>Spécifications de la peinture</i>	7

RIDUTTORI PENDOLARI SERIE TA
SHAFT MOUNTED GEARBOXES SERIES TA
AUFSTECKGETRIEBE TYP TA
REDUCTEURS PENDULAIRES SERIE TA

12	Caratteristiche costruttive	<i>Design characteristics</i>	Konstruktive Eigenschaften	<i>Caractéristiques de construction</i>	8
13	Designazione	<i>Designation</i>	Bezeichnung	<i>Désignation</i>	9
14	Dispositivo antiretro	<i>Anti-run back device</i>	Rückklasperr	<i>Dispositif anti-devireur</i>	10
15	Lubrificazione	<i>Lubrication</i>	Schmierung	<i>Lubrification</i>	11
16	Posizioni di montaggio	<i>Mounting positions</i>	Einbaulagen	<i>Positions de montage</i>	12
17	Carichi radiali	<i>Overhung loads</i>	Radialkräfte	<i>Charges radiales</i>	15
18	Dati tecnici	<i>Rating charts</i>	Auswahltabellen	<i>Données techniques</i>	16
19	Dimensioni	<i>Dimensions</i>	Abmessungen	<i>Dimensions</i>	19
20	Accessori	<i>Accessoires</i>	Zubehör	<i>Accessoires</i>	29

Revisionsi
 L'indice di revisione del catalogo è riportato a pag. 30.
 Al sito www.bonfiglioli.com sono disponibili i cataloghi con le revisioni aggiornate.

Revisions
 Refer to page 30 for the catalogue revision index.
 Visit www.bonfiglioli.com to search for catalogues with up-to-date revisions.

Änderungen
 Das Revisionsverzeichnis des Katalogs wird auf Seite 30 wiedergegeben. Auf unserer Website www.bonfiglioli.com werden die Kataloge in ihrer letzten, überarbeiteten Version angeboten.

Révisions
 Le sommaire de révision du catalogue est indiqué à la page 30.
 Sur le site www.bonfiglioli.com des catalogues avec les dernières révisions sont disponibles.

**INFORMAZIONI GENERALI****1 - COPPIA****Coppia nominale** **M_{n2} [Nm]**

È la coppia trasmissibile in uscita con carico continuo uniforme, riferita alla velocità in ingresso n_1 e a quella corrispondente in uscita n_2 .

È calcolata in base ad un fattore di servizio $f_s = 1$.

Coppia richiesta **M_{r2} [Nm]**

Rappresenta la coppia richiesta dall'applicazione e dovrà sempre essere uguale o inferiore alla coppia in uscita nominale M_{n2} del riduttore scelto.

Coppia di calcolo **M_{c2} [Nm]**

È il valore di coppia da utilizzare per la selezione del riduttore considerando la coppia richiesta M_{r2} e il fattore di servizio f_s ed è dato dalla formula:

GENERAL INFORMATION**1 - TORQUE****Rated torque** **M_{n2} [Nm]**

The torque that can be transmitted continuously through the output shaft, with the gear unit operated under a service factor $f_s = 1$.

Rating is speed sensitive.

Required torque **M_{r2} [Nm]**

The torque demand based on application requirement.

It must always be equal to or less than torque M_{n2} the gearbox under study is rated for.

Calculated torque **M_{c2} [Nm]**

Computational torque value to be used when selecting the gearbox.

It is calculated considering the required torque M_{r2} and service factor f_s , as per the equation here after:

ALLGEMEINEINFORMATIONEN**1 - ABTRIEBSMOMENT****Nenn-Drehmoment** **M_{n2} [Nm]**

Dies ist das an der Abtriebswelle übertragbare Drehmoment bei gleichförmiger Dauerbelastung bezogen auf die Antriebsdrehzahl n_1 und die entsprechende Abtriebsdrehzahl n_2 .

Das Drehmoment wird auf Grundlage eines Betriebsfaktor $f_s = 1$ berechnet.

Verlangtes Drehmoment **M_{r2} [Nm]**

Dies ist das von der Anwendung verlangte Drehmoment, das stets kleiner oder gleich dem Nenn-Abtriebsmoment M_{n2} des gewählten Getriebes sein muß.

Soll-Drehmoment **M_{c2} [Nm]**

Dies ist das bei der Wahl des Getriebes zugrundezulegende Drehmoment, wobei das übertragene Drehmoment M_{r2} und der Betriebsfaktor f_s zu berücksichtigen sind; das Soll-Drehmoment wird mit folgender Gleichung berechnet:

INFORMATIONS GENERALES**1 - COUPLE****Couple nominal** **M_{n2} [Nm]**

C'est le couple transmissible en sortie avec une charge continue uniforme se référant à la vitesse en entrée n_1 et à celle correspondante en sortie n_2 .

Il est calculé sur la base d'un facteur de service $f_s = 1$.

Couple requis **M_{r2} [Nm]**

Il représente le couple requis par l'application et devra toujours être inférieur ou égal au couple en sortie nominal M_{n2} du réducteur choisi.

Couple de calcul **M_{c2} [Nm]**

C'est la valeur de couple à utiliser pour la sélection du réducteur en considérant le couple requis M_{r2} et le facteur de service f_s et s'obtient avec la formule:

$$M_{c2} = M_{r2} \cdot f_s < M_{n2} \quad (1)$$

2 - POTENZA**Potenza nominale in entrata** **P_{n1} [kW]**

Nelle tabelle di selezione dei riduttori è la potenza applicabile in entrata riferita alla velocità n_1 , considerando un fattore di servizio $f_s = 1$.

2 - POWER**Rated power** **P_{n1} [kW]**

In the gearbox selection charts this is the power applicable to input shaft, based on input speed n_1 and corresponding to service factor $f_s = 1$.

2 - LEISTUNG**Leistung Antriebswelle** **P_{n1} [kW]**

In den Tabellen für die Wahl der Getriebe ist die an der Antriebswelle übertragbare Leistung auf die Drehzahl n_1 bezogen und es wurde ein Betriebsfaktor $f_s = 1$ angenommen.

2 - PUISSANCE**Puissance en entrée** **P_{n1} [kW]**

Dans les tableaux de sélection des réducteurs, c'est la puissance applicable en entrée se rapportant à la vitesse n_1 et en considérant un facteur de service $f_s = 1$.

3 - VELOCITÀ ANGOLARE**Velocità in entrata** **n_1 [min^{-1}]**

È la velocità relativa al tipo di motorizzazione scelta; i valori di catalogo si riferiscono alle velocità dei motori elettrici comunemente usati a singola e doppia polarità.

Se il riduttore riceve il moto da una trasmissione in entrata, è sempre preferibile adottare velocità inferiori a 1400 min^{-1} al fine di garantire condizioni ottimali di funzionamento.

Velocità in entrata superiori sono ammesse considerando il naturale declassamento della coppia nominale M_{n2} del riduttore.

3 - ANGULAR VELOCITY**Input speed** **n_1 [min^{-1}]**

The speed is related to the prime mover selected. Catalogue values refer to speed of either single or double speed motors that are common in the industry.

If the gearbox is driven by an external transmission it is recommended to operate it with a speed of 1400 min^{-1} , or lower, in order to optimise operating conditions and lifetime.

Higher input speeds are permitted, however in this case consider that torque rating M_{n2} is affected adversely. Please consult a Bonfiglioli representative.

3 - DREHZAHL**Drehzahl Antriebswelle** **n_1 [min^{-1}]**

Dies ist die vom gewählten Motortyp abhängige Drehzahl. Die Katalogangaben beziehen sich auf die Drehzahl von allgemein üblichen eintourigen Elektromotoren oder von polumschaltbaren Elektromotoren.

Um optimale Betriebsbedingungen zu gewährleisten, ist stets eine Antriebsdrehzahl unter 1400 min^{-1} zu empfehlen.

Höhere Antriebsdrehzahlen sind zulässig, wobei die zwangsläufige Herabsetzung des Nenn-Abtriebsdrehmoments M_{n2} des Getriebes zu berücksichtigen ist.

3 - VITESSE ANGULAIRE**Vitesse d'entrée** **n_1 [min^{-1}]**

C'est la vitesse relative au type de motorisation choisie. Les valeurs de catalogue se réfèrent aux vitesses des moteurs électriques à simple et double polarité communément utilisés.

Si le réducteur reçoit le mouvement d'une transmission en entrée, il est toujours préférable d'adopter des vitesses inférieures à 1400 min^{-1} afin de garantir des conditions optimales de fonctionnement.

Des vitesses d'entrée supérieures sont admises en considérant le déclassement naturel du couple nominal M_{n2} du réducteur.



Velocità in uscita
 n_2 [min^{-1}]

È in funzione della velocità in entrata n_1 e del rapporto di riduzione i secondo la relazione:

Output speed
 n_2 [min^{-1}]

The output speed value n_2 is calculated from the relationship of input speed n_1 to the gear ratio i , as per the following equation:

Abtriebsdrehzahl
 n_2 [min^{-1}]

Sie ist abhängig von der Antriebsdrehzahl n_1 und dem Übersetzungs i nach folgender Gleichung:

Vitesse en sortie
 n_2 [min^{-1}]

Elle varie en fonction de la vitesse d'entrée n_1 et du rapport de réduction i selon l'équation:

$$n_2 = \frac{n_1}{i} \quad (2)$$

4 - FATTORE DI SERVIZIO f_s

Il fattore di servizio è il parametro che traduce in un valore numerico la gravosità del servizio che il riduttore è chiamato a svolgere, tenendo conto, benché con inevitabile approssimazione, del funzionamento giornaliero, della variabilità del carico e di eventuali sovraccarichi, connessi con la specifica applicazione del riduttore.

Indipendentemente dal valore così ricavato del fattore di servizio, segnaliamo che esistono applicazioni fra le quali, a puro titolo di esempio i sollevamenti, per le quali il cedimento di un organo del riduttore potrebbe esporre il personale che opera nelle immediate vicinanze a rischio di ferimento.

Se esistono dubbi che l'applicazione possa presentare questa criticità vi invitiamo a consultare preventivamente il ns. Servizio Tecnico.

4 - SERVICE FACTOR f_s

This factor is the numeric value describing reducer service duty. It takes into consideration, with unavoidable approximation, daily operating conditions, load variations and overloads connected with reducer application. Regardless to the value given for the service factor, we would like to remind that in some applications, which for example involve lifting of parts, failure of the reducer may expose the operators to the risk of injuries. If in doubt, please contact our Technical Service.

4 - BETRIEBSFAKTOR f_s

Beim Betriebsfaktor handelt es sich um den Parameter, der die Betriebsbelastung, die das Getriebe aushalten muss, in einem Wert ausdrückt. Dabei berücksichtigt er, auch wenn nur mit einer unvermeidbaren Annäherung, den täglichen Einsatz, die unterschiedlichen Belastungen und eventuelle Überbelastungen, die mit der spezifischen Applikation des Getriebes verbunden sind. Unabhängig von dem so erhaltenen Betriebsfaktor, möchten wir Sie darauf hinweisen, dass es Applikationen gibt, unter denen beispielsweise auch die Hebefunktionen zu finden sind, bei denen das Nachgeben eines Getriebeorgans, das in dessen Nähe arbeitende Personal einer Verletzungsgefahr aussetzen könnte. Sollten daher Zweifel darüber bestehen, ob die entsprechende Applikation sich in diesem Bezug als kritisch erweist, bitten wir Sie sich zuvor mit unserem Technischen Kundendienst in Verbindung zu setzen.

4 - FACTEUR DE SERVICE f_s

Le facteur de service est le paramètre qui traduit en une valeur numérique la difficulté du service que le réducteur est appelé à effectuer en tenant compte, avec une approximation inévitable, du fonctionnement journalier, de la variabilité de la charge et des éventuelles surcharges liées à l'application spécifique du réducteur.

Indépendamment de la valeur du facteur de service ainsi trouvée, nous signalons qu'il existe des applications parmi lesquelles, à titre d'exemple, les levages, pour lesquels la rupture d'un organe du réducteur pourrait exposer le personnel opérant à proximité immédiate à des risques de lésion.

En cas de doute concernant les risques éventuels de l'application, nous vous conseillons de contacter préalablement notre Service Technique.

(A1)

Avviamenti orari Starts per hour Shaltungen pro Stunde Démarrages/heure Z	Servizio Duty Belastung Charge	Ore di funzionamento giornaliera Daily operating hours Tägliche Betriebsstunden Durée de fonctionnement par jour			
		$h \leq 0.5$	$0.5 < h \leq 2$	$2 < h \leq 10$	$10 < h < 24$
$Z < 10$	carico uniforme / uniform loading Gleichmäßige Belastung / charge uniforme	0.8	0.9	1.0	1.25
	moderato sovraccarico / moderate shock loading Belastung mit mäßige Stößen / charge avec chocs modérés	0.9	1.0	1.25	1.5
	elevato sovraccarico / heavy shock loading Belastung mit starken Stößen / charge avec chocs importants	1.0	1.25	1.5	1.75
$Z \geq 10$	carico uniforme / uniform loading Gleichmäßige Belastung / charge uniforme	0.9	1.0	1.25	1.5
	moderato sovraccarico / moderate shock loading Belastung mit mäßige Stößen / charge avec chocs modérés	1.0	1.25	1.5	1.75
	elevato sovraccarico / heavy shock loading Belastung mit starken Stößen / charge avec chocs importants	1.25	1.5	1.75	2.0

I valori sopra indicati devono essere moltiplicati per 1.2 in caso di:
- funzionamento con inversioni
- sovraccarico applicato in modo istantaneo

Values listed above must be multiplied by 1.2 in case of:
- reversing operation
- shock loading applying instantaneously

Die o.g. Werte müssen mit 1,2 vervielfältigt werden bei:
- Betriebsumsteuerung
- Augenblicklicher Überlast

Les valeurs sur indiqués doivent être multipliées pour 1,2 en cas de :
- fonctionnement avec des inversions
- surcharge appliqué en facon instantanée



5 - MANUTENZIONE

Si consiglia di effettuare una prima sostituzione del lubrificante dopo circa 300 ore di funzionamento provvedendo ad un accurato lavaggio interno del gruppo con adeguati detergenti. Evitare di miscelare olii a base minerale con olii sintetici. Controllare periodicamente il livello del lubrificante effettuando la sostituzione indicativamente agli intervalli riportati nella tabella seguente.

5 - MAINTENANCE

The first oil change must take place after about 300 hours of operation, carefully flushing the gear unit using suitable detergents. Do not mix mineral oils with synthetic oils. Check oil level regularly and change oil at the intervals shown in the following table.

5 - WARTUNG

Bei den übrigen Getrieben wird ein erster Ölwechsel nach ca. 300 Betriebsstunden empfohlen, wobei das Innere der Gruppe sorgfältig mit einem geeigneten Reinigungsmittel zu waschen ist. Mineralöle nicht mit Syntheseölen mischen. Den Ölstand regelmäßig kontrollieren und den Ersatz in Zeitabständen, wie in der angegebenen Tabelle, durchführen:

5 - ENTRETIEN

Nous conseillons d'effectuer une première vidange du lubrifiant après les 300 premières heures de fonctionnement en réalisant un lavage soigné à l'intérieur du groupe avec des produits détergents appropriés. Éviter de mélanger les huiles à base minérale avec des huiles synthétiques. Contrôler périodiquement le niveau du lubrifiant en effectuant les vidanges conformément aux intervalles indiqués dans le tableau ci suivante.

(A2)

Temperatura olio / Oil temperature Öltemperatur / Température huile [°C]	Intervallo di lubrificazione / Oil change interval Schmierfrist / Intervalle de lubrification [h]	
	olio minerale / mineral oil Mineralöl / huile minérale	olio sintetico / synthetic oil Syntheseöl / huile synthétique
< 65	8000	25000
65 - 80	4000	15000
80 - 95	2000	12500

6 - SELEZIONE

- a) Determinare il fattore di servizio f_s .
- b) Conoscendo la coppia M_{r2} di uscita richiesta dalla applicazione, si procede alla definizione della coppia di calcolo:

6 - SELECTION

- a) *Determine service factor f_s .*
- b) *Assuming the required output torque for the application M_{r2} is known, the calculation torque can be then defined as:*

6 - ANTRIEBSAUSWAHL

- a) Den Betriebsfaktor f_s bestimmen.
- b) Anhand des bekannten von der Anwendung geforderten Abtriebsdrehmoments M_{r2} das Soll-Drehmoment bestimmen:

6 - SELECTION

- a) *Déterminer le facteur de service f_s .*
- b) *En connaissant le couple M_{r2} de sortie requis par l'application, l'on procède à la définition du couple de calcul:*

$$M_{c2} = M_{r2} \cdot f_s \quad (3)$$

- c) In base alla velocità in uscita n_2 richiesta, e a quella in entrata n_1 disponibile, si calcola il rapporto di riduzione:

- c) *The gear ratio is calculated according to requested output speed n_2 and drive speed n_1 :*

- c) Auf Grundlage der verlangten Abtriebsdrehzahl n_2 und der verfügbaren Antriebsdrehzahl n_1 die Übersetzung berechnen:

- c) *Suivant la vitesse en sortie n_2 requise et celle en entrée n_1 disponible, l'on calcule le rapport de réduction:*

$$i = \frac{n_1}{n_2} \quad (4)$$

Disponendo dei dati M_{c2} e i , si ricercherà nelle tabelle corrispondenti alla velocità n_1 il riduttore che, in funzione del rapporto $[i]$ più prossimo a quello calcolato, proponga una coppia nominale:

Once values for M_{c2} and i are known consult the rating charts under the appropriate input speed n_1 and locate the gear unit that features the gear ratio closest to $[i]$ and at same time offers a rated torque value M_{n2} so that:

Anhand der Werte für M_{c2} und i in den Tabellen für die Drehzahl n_1 das Getriebe auswählen, das in Abhängigkeit von einer Übersetzung $[i]$, die dem Sollwert möglichst nahe ist, folgendes Nenn-Drehmoment erlaubt:

En disposant des données M_{c2} et i , l'on recherchera dans les tableaux correspondant à la vitesse n_1 le réducteur qui, en fonction du rapport $[i]$ le plus proche de celui calculé, propose un couple nominal:

$$M_{n2} \geq M_{c2} \quad (5)$$



7 - VERIFICHE

Carichi radiali

Verificare che i carichi radiali agenti sugli alberi di entrata e/o uscita rientrino nei valori di catalogo ammessi. Se superiori, aumentare la grandezza del riduttore oppure modificare la supportazione del carico.

Ricordiamo che tutti i valori indicati nel catalogo si riferiscono a carichi agenti sulla mezzeria della sporgenza dell'albero in esame per cui, in fase di verifica, è indispensabile tenere conto di questa condizione provvedendo, se necessario, a determinare con le apposite formule il carico ammissibile alla distanza x_{1-2} desiderata.

A tale proposito si rimanda ai paragrafi relativi ai carichi radiali.

7 - VERIFICATION

Radial loads

Make sure that radial forces applying on input and/or output shaft are within permitting catalogue values.

If they were higher consider designing a different bearing arrangement before switching to a larger gear unit.

Catalogue values for rated overhung loads refer to mid-point of shaft under study.

Should application point of the overhung load be localised further out the revised loading capability must be adjusted as per instructions given in this manual. See paragraph 17.

7 - PRÜFUNGEN

Radialkräfte

Sicherstellen, daß die auf die Antriebswellen und/oder Abtriebswellen wirkenden Radialkräfte innerhalb der zulässigen Katalogwerte liegen. Wenn sie höher sind, das Getriebe größer dimensionieren bzw. die Abstützung der Last verändern. Wir erinnern daran, daß alle im Katalog angegebenen Werte sich auf Kräfte beziehen, die auf die Mitte des Wellenendes wirken. Diese Tatsache muß bei der Prüfung unbedingt berücksichtigt werden und nötigenfalls muß mit Hilfe der geeigneten Formeln die zulässige Kraft beim gewünschten Abstand x_{1-2} bestimmt werden. Siehe hierzu die Erläuterungen zu den Radialkräften in diesem Katalog.

7 - VERIFICATIONS

Charges radiales

Vérifier que les charges radiales agissant sur les arbres d'entrée et/ou de sortie se situent dans les valeurs de catalogue admises. Si elles sont supérieures, choisir la taille du réducteur supérieure ou modifier la reprise de charge. Rappelons que toutes les valeurs indiquées dans le catalogue se réfèrent à des charges agissant au milieu de la longueur disponible de l'arbre contrôlé. Par conséquent, en phase de vérification, il est indispensable de prendre en considération cette condition en déterminant, si nécessaire, avec les formules appropriées, la charge admissible à la distance x_{1-2} désirée. Se rapporter à ce propos aux paragraphes relatifs aux charges radiales.

Carichi assiali

Anche gli eventuali carichi assiali dovranno essere confrontati con i valori ammissibili.

Se si è in presenza di carichi assiali molto elevati o combinati con carichi radiali, si consiglia di interpellare il ns. Servizio Tecnico.

Thrust loads

Actual thrust load must be found within 20% of the equivalent overhung load capacity.

Should an extremely high, or a combination of radial and axial load apply, consult Bonfiglioli Technical Service.

Axialkräfte

Auch die eventuell vorhandenen Axialkräfte müssen mit den im Katalog angegebenen zulässigen Werten verglichen werden. Wenn sehr hohe Axialkräfte wirken oder Axialkräfte in Kombination mit Radialkräften, bitte unseren Technischen Kundendienst zu Rate ziehen.

Charges axiales

Les éventuelles charges axiales devront être comparées avec les valeurs admissibles. Si l'on est en présence de charges axiales très élevées ou combinées avec des charges radiales, nous conseillons d'interpeller notre Service Technique.

8 - INSTALLAZIONE

È molto importante, per l'installazione del riduttore, attenersi alle seguenti norme:

a) Assicurarsi che il fissaggio del riduttore, sia stabile onde evitare qualsiasi vibrazione. Installare (se si prevedono urti, sovraccarichi prolungati o possibili bloccaggi) giunti idraulici, frizioni, limitatori di coppia, ecc.

b) Durante la verniciatura si dovranno proteggere i piani lavorati e il bordo esterno degli anelli di tenuta per evitare che la vernice ne essichi la gomma, pregiudicando la tenuta del paraolio stesso.

c) Prima della messa in servizio del riduttore accertarsi che la macchina che lo incorpora sia in regola con le

8 - INSTALLATION

The following installation instructions must be observed:

a) *Make sure that the gearbox is correctly secured to avoid vibrations. If shocks or overloads are expected, install hydraulic couplings, clutches, torque limiters, etc.*

b) *Before being paint coated, the machined surfaces and the outer face of the oil seals must be protected to prevent paint drying out the rubber and jeopardising the sealing function.*

c) *Prior to putting the gear unit into operation make sure that the equipment that incorporates the same com-*

8 - INSTALLATION

Für die Installation des Getriebes ist es äußerst wichtig, daß folgende Normen beachtet werden:

a) Sicherstellen, daß die Befestigung des Getriebes stabil ist, damit keine Schwingungen entstehen. Wenn es voraussichtlich zu Stößen, längerdauernden Überlasten oder zu Blockierungen kommen kann, sind entsprechende Schutzelemente wie hydraulische Kupplungen, Kupplungen, Rutschkupplungen usw. zu installieren.

b) Beim Lackieren die bearbeiteten Flächen und die Dichtringe schützen, damit der Anstrichstoff nicht dem Kunststoff angreift und somit die Dichtigkeit der Ölabdichtungen in Frage gestellt wird.

c) Bevor das Getriebe im Betrieb zu setzen, muß man sich vergewissern daß die das Getriebe einbauende

8 - INSTALLATION

Il est très important, pour l'installation du réducteur, de se conformer aux règles suivantes:

a) *S'assurer que la fixation du réducteur soit stable afin d'éviter toute vibration. Installer (en cas de chocs, de surcharges prolongées ou de blocages) des couplages hydrauliques, des embrayages, des limiteurs de couple etc...*

b) *En phase de peinture, il faudra protéger les plans usinés et le bord extérieur des bagues d'étanchéité pour éviter que la peinture ne dessèche le caoutchouc, ce qui risque de nuire à l'efficacité du joint.*

c) *Avant la mise en service du réducteur, vérifier que la machine où il est monté est conforme aux normes de la*



disposizioni della Direttiva Macchine 89/392 e successivi aggiornamenti.

plies with the current revision of the Machines Directive 89/392.

Maschine gemäß den aktuellen Regelungen der Maschine Richtlinie 89/392 ist.

Directive Machines 89/392 et ses mises à jour.

- d) Prima della messa in funzione della macchina, accertarsi che la posizione del livello del lubrificante sia conforme alla posizione di montaggio del riduttore e che la viscosità sia adeguata al tipo del carico (vedi tabella A4).
- d) *Before starting up the machine, make sure that oil level conforms to the mounting position specified for the gear unit and the viscosity is suitable for the duty the gearbox will be operated with. See chart (A4) for reference.*
- d) Vor Inbetriebnahme der Maschine sicherstellen, daß die Anordnung der Füllstandschrabe der Einbaulage angemessen ist, und die Viskosität des Schmiermittels der Belastungsart entspricht (siehe Tabelle A4).
- d) *Avant la mise en marche de la machine, s'assurer que la position du niveau du lubrifiant soit conforme à la position de montage du réducteur et que la viscosité soit appropriée au type de charge (voir tableau A4).*
- e) Nel caso di installazione all'aperto prevedere adeguate protezioni e/o carterture allo scopo di evitare l'esposizione diretta agli agenti atmosferici e alla radiazione solare.
- e) *For outdoor installation provide adequate guards in order to protect the drive from rainfalls as well as direct sun radiation.*
- e) Bei Inbetriebnahme in Frein, muß man geeigneten Schutzgeräte vorsehen, um das Antrieb gegen Regen und direkte Sonnenstrahlung zu schützen.
- e) *En cas d'installation en plein air, il est nécessaire d'appliquer des protections et/ou des caches appropriés de façon à éviter l'exposition directe aux agents atmosphériques et aux rayonnements solaires.*

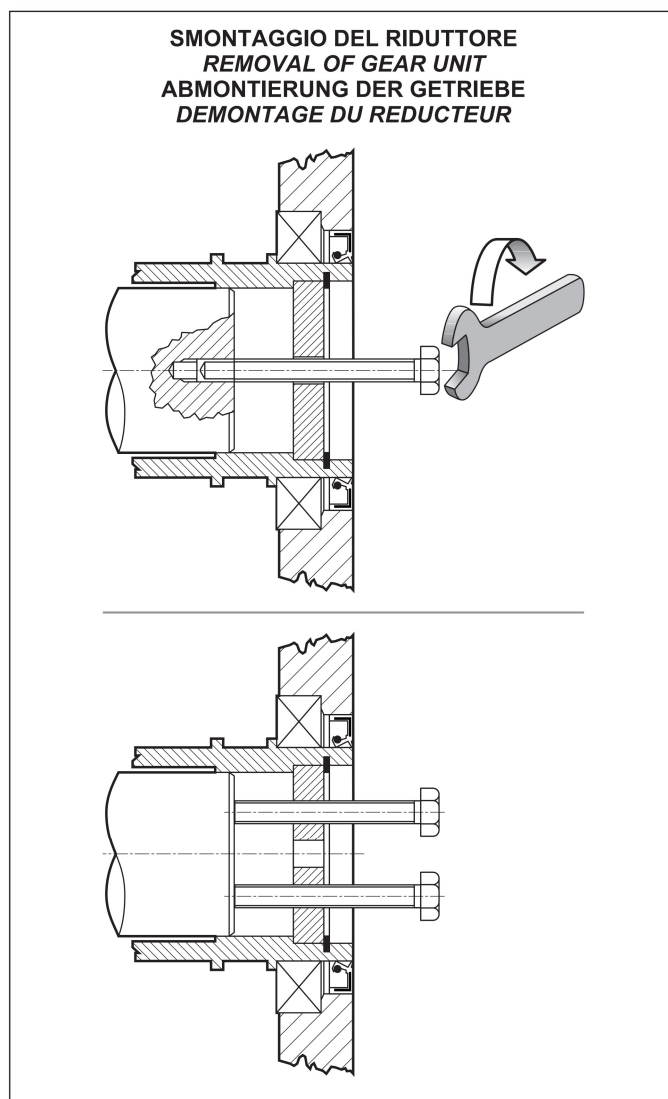
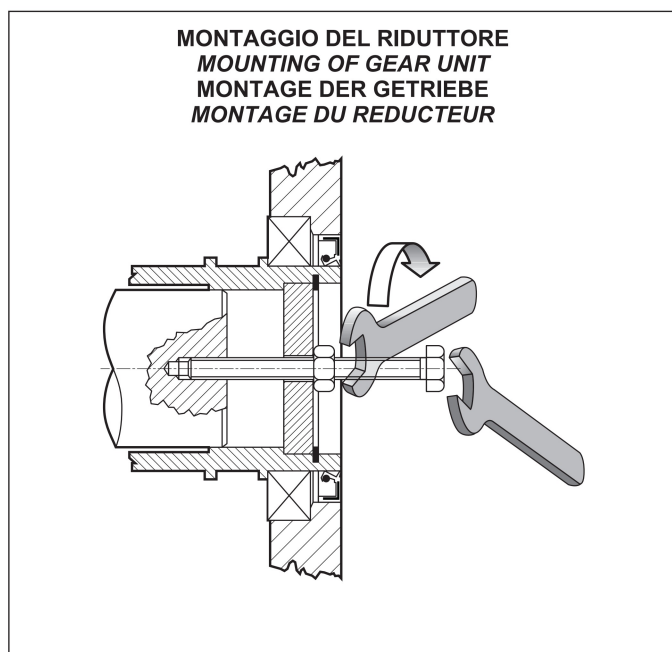

Le superfici di contatto dovranno essere pulite e trattate con adeguati protettivi prima del montaggio, onde scongiurare l'ossidazione e il conseguente bloccaggio delle parti.

Before assembling, the contact surfaces must be clean and treated with adequate protective against rust and blocking.

Die chemische Reinigung der Behrungsfläche bevor der Montage ist notwendig um die Oxydierung und die Blockierung der Teile zu vermeiden.

Les surfaces de contact devront être propre et traitées avec adéquats protectives avant du montage, pour éviter l'oxydation et le conséquent blocage des les parties.



9 - STOCCAGGIO

Il corretto stoccaggio dei prodotti ricevuti richiede l'esecuzione delle seguenti attività:

- a) Escludere aree all'aperto, zone esposte alle intemperie o con eccessiva umidità.
- b) Interporre sempre tra il pavimento ed i prodotti, pianali lignei o di altra natura, atti ad impedire il diretto contatto col suolo.
- c) Per periodi di stoccaggio e soste prolungate le superfici interessate agli accoppiamenti quali flange, alberi e giunti devono essere protette con idoneo prodotto antiossidante (Mobilarma 248 o equivalente).
In questo caso i riduttori dovranno essere posizionati con il tappo di sfianto nella posizione più alta e riempiti interamente d'olio.
Prima della loro messa in servizio nei riduttori dovrà essere ripristinata la corretta quantità, e il tipo di lubrificante.

9 - STORAGE

Observe the following instructions to ensure correct storage of the products:

- a) *Do not store outdoors, in areas exposed to weather or with excessive humidity.*
- b) *Always place boards, wood or other material between the products and the floor. The gearboxes should not have direct contact with the floor.*
- c) *In case of long-term storage all machined surfaces such as flanges, shafts and couplings must be coated with a suitable rust inhibiting product (Mobilarma 248 or equivalent). Furthermore gear units must be placed with the fill plug in the highest position and filled up with oil. Before putting the units into operation the appropriate quantity, and type, of oil must be restored.*

9 - LAGERUNG

Die korrekte Lagerung der Antriebe erfordert folgende Vorkehrungen:

- a) Die Produkte nicht im Freien lagern und nicht in Räumen, die der Witterung ausgesetzt sind, oder eine hohe Feuchtigkeit aufweisen.
- b) Die Produkte nie direkt auf dem Boden, sondern auf Unterlagen aus Holz oder einem anderen Material lagern.
- c) Bei anhaltenden Lager- und Haltszeiten müssen die Oberflächen für die Verbindung, wie Flansche, Wellen oder Kupplungen mit einem geeigneten Oxidationsschutzmittel behandelt werden (Mobilarma 248 oder ein äquivalentes Mittel).
Übrigens müssen die Getriebe mit nach oben gerichteter Entlüftungsschraube gelagert und mit Öl gefüllt werden.
Die Getriebe müssen vor ihrer Verwendung mit der angegebenen Menge des vorgesehenen Schmiermittels gefüllt werden.

9 - STOCKAGE

Un correct stockage des produits reçus nécessite de respecter les règles suivantes:

- a) *Exclure les zones à ciel ouvert, les zones exposées aux intempéries ou avec humidité excessive.*
- b) *Interposer dans tous les cas entre le plancher et les produits des planches de bois ou des supports d'autre nature empêchant le contact direct avec le sol.*
- c) *Pour un stockage de long durée il faut protéger les surfaces d'accouplement (brides, arbres, manchon d'accouplement) avec produit anti oxydant (Mobilarma 248 ou équivalent). Dans ce cas les réducteurs devront être placés avec bouchon reniflard vers le haut et complètement rempli d'huile. Avant de la mise en service du réducteur, la bon quantité d'huile devra être rétabli selon la quantité indiquée sur le catalogue.*

10 - CONDIZIONI DI FORNITURA

I riduttori vengono forniti come segue:

- a) già predisposti per essere installati nella posizione di montaggio come definito in fase di ordine;
- b) collaudati secondo specifiche interne;
- c) dotati di protezioni in plastica sugli alberi;
- d) provvisti di golfare di sollevamento (dove previsto).

10 - CONDITIONS OF SUPPLY

Gear units are supplied as follows:

- a) *configured for installation in the mounting position specified when ordering;*
- b) *tested to manufacturer specifications;*
- c) *shafts are protected during transportation by plastic caps;*
- d) *supplied with lifting lug (where applicable).*

10 - LIEFERBEDINGUNGEN

Die Getriebe werden in folgendem Zustand geliefert:

- a) schon bereit für die Montage in der bei Bestellung festgelegten Einbaulage;
- b) nach werksinternen Spezifikationen geprüft;
- c) alle Getriebe werden mit Kunststoffschutz auf den Wellen geliefert;
- d) mit Transportriering zum Anheben (falls vorgesehen).

10 - CONDITIONS DE LIVRAISON

Les réducteurs sont livrés comme suit:

- a) *déjà prédisposés pour être installés dans la position de montage comme défini en phase de commande;*
- b) *testés selon les spécifications internes;*
- c) *embouts de protections en plastique sur les arbres;*
- d) *dotés d'un crochet de levage (quand cela est prévu).*

11 - SPECIFICHE DELLA VERNICE

Le specifiche della vernice applicata sui riduttori (dove previsto) potranno essere richieste alle filiali o ai distributori che hanno fornito i gruppi.

11 - PAINT SPECIFICATIONS

Specifications for paint applied to gearboxes (where applicable) may be obtained from the branches or dealers that supplied the units.

11 - ANGABEN ZU DEN ANSTRICHSTOFFE

Die Spezifikationen des Lackes, der auf den Getriebe (wo erforderlich) verwendet wurde, können bei den Filialen oder Verkaufsstellen, die die Gruppen geliefert haben, angefordert werden.

11 - SPECIFICATIONS DE LA PEINTURE

Les spécification de la peinture appliquée sur les réducteurs pourront, le cas échéant, être demandées aux filiales ou aux distributeurs ayant fourni les groupes.



12 - CARATTERISTICHE COSTRUTTIVE

Le caratteristiche costruttive salienti sono:

- rendimenti elevati
- basso livello di rumorosità
- ingranaggi in acciaio legato cementati e temprati, escluso la corona del riduttore TA 30
- casse in ghisa ad alta resistenza, verniciate.

12 - DESIGN FEATURES

The main design characteristics are:

- *high efficiency*
- *quite operation*
- *gears from case hardened and hardened alloy steel, except gearwheel for TA 30*
- *gear case from cast iron. All units are paint coated as standard.*

12 - KONSTRUKTIVE EIGENSCHAFTEN

Die wichtigsten konstruktiven Eigenschaften sind:

- hohe Wirkungsgrade
- niedriger Geräuschpegel
- Zahnräder einsatzgehärtet und gehärteten legierten Stahl, mit Ausnahme von Zahnrad für TA 30
- hochwiderstandsfähige und lackierte Gußgehäuse.

12 - CARACTERISTIQUES DE CONSTRUCTION

Les principales caractéristiques de construction sont:

- *rendements élevés*
- *faible niveau de bruit*
- *Engrenages en acier allié cémenté et trempé, à l'exception de la couronne pour le reducteur TA 30*
- *carters en fonte à haute résistance peints.*

(A3)

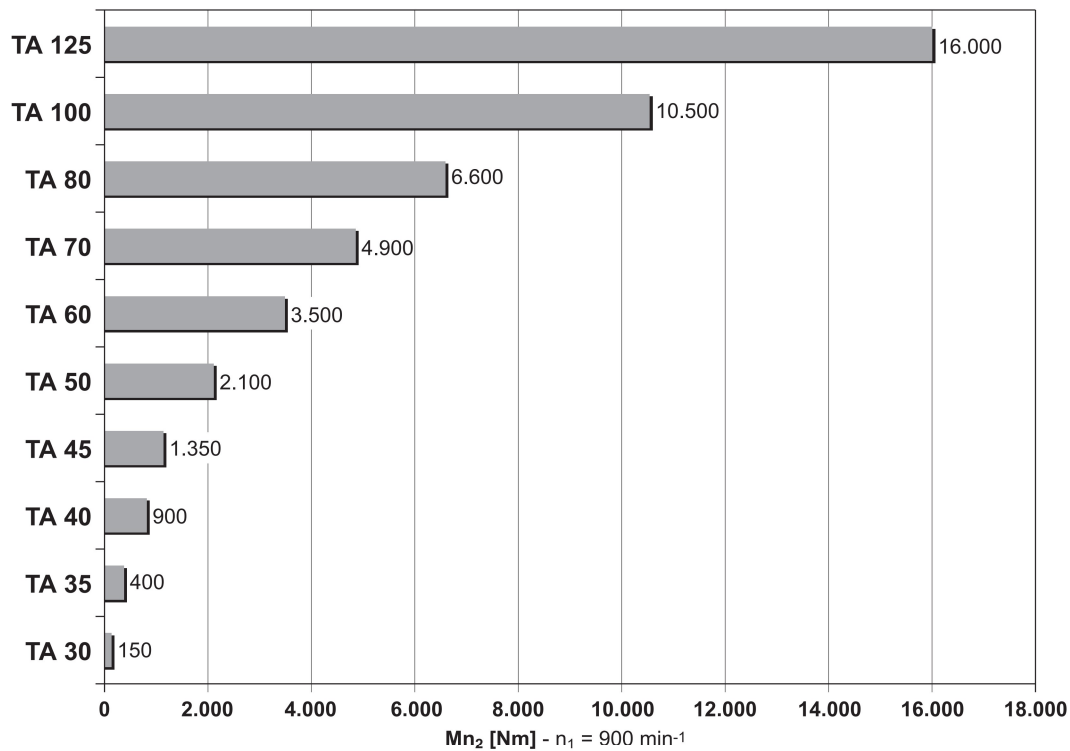



13 - DESIGNAZIONE

13 - DESIGNATION

13 - BEZEICHNUNG

13 - DESIGNATION

TA 35 35 D A 15 HS B ...

OPZIONI / *OPTIONS*
OPTIONEN / *OPTIONS*

10

POSIZIONE DI MONTAGGIO / *MOUNTING POSITION*
EINBAULAGEN / *POSITION DE MONTAGE*

12

A B C D VA VB

CONFIGURAZIONE ALBERO VELOCE / *INPUT SHAFT CONFIGURATION*
BEZEICHNUNG DER ANTRIEBESSEITE / *DESIGNATION ENTREE*

HS Albero cilindrico / *solid input shaft*
cylindrischer Antriebswelle / *arbre rapide cylindrique*

080 B5 Predisposizione motore standard IEC (Solo TA 30)
IEC-motor mounting flange (TA 30 only)

090 B5 Getriebe vorbereitet für IEC-Motor (Nür TA 30)
Réducteur prédisposé pour liaison a moteur IEC (Seulement TA 30)

RAPPORTO DI TRASMISSIONE / *GEAR RATIO*
ÜBERSETZUNG / *RAPPORT DE REDUCTION*

i

DISPOSITIVO ANTIRETRO / *ANTI-RUN BACK DEVICE*
RÜCKLAUFSPERRE / *DISPOSITIF ANTI-RETOUR*

A antiretro fornito con rotazione libera DESTRA (Escluso TA 30)
anti-runback fitted allowing the RIGHT direction of rotation (Excluding TA 30)
Rücklaufsperr für die RECHTS Richtung der Umdrehung (Ausgenommen TA 30)
anti-retour fournis avec rotation libre DROITE (Sauf TA 30)

- anti retro non fornito / *anti-runback not specified*
Ohne Rücklaufsperr / *pas de anti-retour*

NUMERO DI RIDUZIONI / *REDUCTIONS*
ANZAHL DER STUFEN / *NOMBRES DES TRAINS*

D riduttore a due stadi / *2-reduction unit*
Getriebe mit 2 Stufen / *reducteur deux trains*

- riduttore a uno stadio / *1-reduction unit*
Getriebe mit 1 Stufe / *reducteur un train*

DIAMETRO ALBERO LENTO / *OUTPUT SHAFT BORE*
ABTRIEBSWELLE DURCHMESSER / *DIAMETRE ARBRE LENT*

35 40 45 50 60 70 80 100 125 135

GRANDEZZA RIDUTTORE / *GEAR FRAME SIZE* / GETRIEBEBAUGRÖSSE / *TAILLE REDUCTEUR*

30 35 40 45 50 60 70 80 100 125

TIPO RIDUTTORE / *GEARBOX TYPE* / GETRIEBETYP / *TYPE DU REDUCTEUR*

TA



Opzioni riduttori

LO

Il riduttore, altrimenti sprovvisto di lubrificante, è fornito dalla fabbrica con carica di olio sintetico. La quantità è funzione della posizione di montaggio specificata.

PV

Dotazione di anelli paraolio con mescola in Viton®.

AL

Specifica della rotazione libera antioraria.

Gearbox options

LO

The gear unit, otherwise supplied unlubricated, is factory filled with synthetic lubricant. Oil quantity is coordinated with the mounting position specified with the ordering.

PV

Oil seals in Viton® compound are fitted.

AL

Specification of the counterclockwise free direction of rotation.

Getriebe Optionen

LO

Das Getriebe ist werksseitig mit synthetischem Öl befüllt. Andernfalls wird das Getriebe ohne Öl ausgeliefert. Die eingefüllte Ölmenge hängt von der Einbaulage ab.

PV

Radialwellendichtringe aus Viton®.

AL

Angabe der Freilaufrichtung (hier links).

Options réducteurs

LO

Le réducteur, autrement pas fourni de lubrifiant, est fourni d'usine avec charge de huile synthétique. La quantité est fonction de la position de montage spécifiée.

PV

Dotation de bagues étanchéité en Viton®.

AL

Spécifique de la rotation libre "gauche".

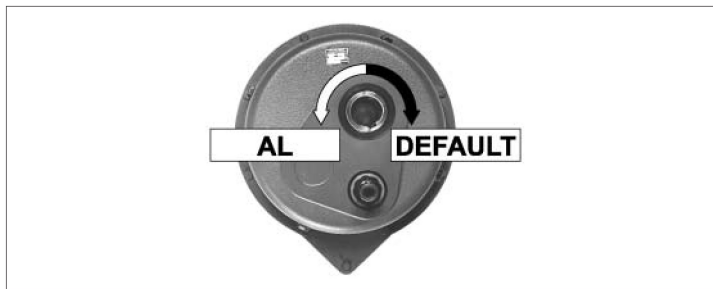

14 - DISPOSITIVO ANTIRETRO

Ad esclusione del riduttore TA 30, a richiesta si può fornire il riduttore munito di dispositivo antiretro (TA.../A - TA.../DA) che permette la rotazione dell'albero lento solo nel senso desiderato.

Se non specificato diversamente il riduttore è fornito con il senso di rotazione libera destro. Se fosse richiesto il senso di rotazione antiorario (sinistro) specificare nell'ordinativo il codice AL.

I riduttori TA nelle grandezze 40, 45, 50, 100 e 125 sono già predisposti per ricevere il dispositivo antiretro BW; per le rimanenti grandezze (35, 60, 70 e 80) dovrà essere richiesto anche il supporto per antiretro (A).

14 - ANTI-RUN BACK DEVICE

With the exception of TA 30, the gearbox can be optionally fitted with an anti-runback device (TA.../A - TA.../DA) which allows the output shaft rotation in one direction only.

Unless otherwise specified, the gearbox is supplied with the clockwise (right hand) free rotation. Should the counterclockwise rotation (left hand) be required please specify option AL when ordering with Bonfiglioli.

Gearboxes of size 40, 45, 50, 100 and 125 are designed to accept the BW anti-runback element as standard. Sizes 35, 60, 70 and 80 need the anti-runback support (A) to be added as well.

14 - RÜCKLAUSPERR

Mit Ausnahme des TA 30, bei Bedarf können die Getriebe mit eingebauter Rücklausperr geliefert werden (TA.../A - TA.../DA), die nur eine Drehrichtung der Abtriebswelle erlauben soll.

Die Drehrichtung ist wählbar und deshalb bei der Bestellung anzugeben (links oder rechts). Wenn nicht anders spezifiziert wird das Getriebe mit Freigängigkeit im Uhrzeigersinn geliefert.

Die Getriebe TA der Grössen 40, 45, 50, 100 und 125 sind so konstruiert, dass sie mit Rücklausperr ausgerüstet werden können, ausgenommen die Grössen 35, 60, 70 und 80, die Aufnahmering für die Rücklausperr benötigen.

14 - DISPOSITIF ANTI-DEVIREUR

A l'exception du réducteur TA 30, sur demande, fourniture possible du réducteur muni d'un antiretour (TA.../A - TA.../DA) qui autorise la rotation de l'arbre lent dans le seul sens souhaité.

Préciser à la commande le sens de rotation (droit ou gauche). Si le sens de rotation souhaité est celui antihoraire, il faudra spécifier le code AL dans la désignation.

Les réducteurs TA des tailles 40, 45, 50, 100 et 125 sont déjà prédisposés pour recevoir le dispositif antiretour BW, pour les autres tailles (35, 60, 70 et 80) il est nécessaire de demander également le support pour antiretour (A).

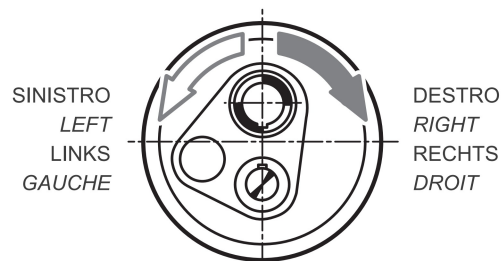
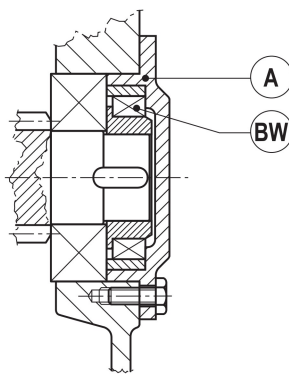



15 - LUBRIFICAZIONE

15 - LUBRICATION

15 - SCHMIERUNG

15 - LUBRIFICATION

Gli organi interni dei riduttori Bonfiglioli sono lubrificati con un sistema misto di immersione e sbattimento dell'olio.

Le tavole che seguono sono da riferimento nell'interpretazione delle posizioni di montaggio, della collocazione dei tappi di servizio e delle quantità di lubrificante.

Queste ultime sono indicative, e per il corretto riempimento si dovrà fare riferimento alla mezzeria del tappo, o dell'astina di livello, se presente.

Rispetto a questa condizione la quantità di lubrificante riportata in tabella può presentare scostamenti, occasionalmente anche rilevanti.

The inner parts of Bonfiglioli gear units are oil-bath and splash lubricated.

The charts here after must be referred to as for the mounting position pattern and the corresponding oil plugs, if applicable, and related lubricant quantity.

Values for the oil quantity are indicative with the proper filling always represented by the center of the sight glass, or the dipstick, when this is supplied.

In some cases, discrepancies, occasionally also substantial, versus the oil quantities listed in the chart may be noticed.

Die Schmierung der Getriebe von Bonfiglioli erfolgt durch eine Kombination aus Ölbad- und Tauchschmierung.

Bitte beachten Sie dazu auch die nachfolgenden Kapitel über die Positionen der Stopfen und Ölschaugläser und den entsprechenden Ölfüllmengen.

Die im Katalog angegebenen Ölfüllmengen sind Anhaltswerte! Maßgebend ist, das der Ölstand bis Mitte des Ölschauglas für die entsprechende Einbaulage aufgefüllt wird.

Auf Abweichungen gegenüber den in der Tabelle angegebenen Ölmengen, gelegentlich nicht unwesentliche, wird hingewiesen.

Les organes internes des réducteurs Bonfiglioli sont lubrifiés avec un système mixte d'immersion et de battement de l'huile.

Les tables suivantes sont de référence dans l'interprétation des positions de montage, du placement des bouchons de service et de la quantité de lubrifiant.

Ces dernières sont indicatives, et pour le correct remplissage il faut faire référence au bouchon de niveau ou à la jauge à huile, si présent.

Par rapport à cette condition la quantité de lubrifiant indiquée dans le tableau peut présenter des écartement, occasionnellement considérables.

(A4)

Viscosità olio ISO VG / Oil viscosity ISO VG / Öl-Viskosität ISO VG / Viscosité de l'huile ISO VG					
	$T_a \leq -20^\circ$	$-20^\circ < T_a \leq 10^\circ$	$0^\circ \leq T_a \leq 30^\circ$	$20^\circ \leq T_a \leq 40^\circ$	$T_a > 40^\circ$
Mineral EP	(*)	150	320	460	460 (*)
PAO EP	(*)	150	220	320	460 (*)
PAG	(*)	150	220	320	460 (*)

PAO Oli sintetici polialfaolefine

PAO Polyalphaolefin synthetic oils

PAO Synthetische Poly-Alpha-Olefin-Öle

PAO Huiles synthétiques polyalphaoléfinés

PAG Oli sintetici a base poliglicolica

PAG Polyglycol-based synthetic oils

PAG Synthetische Öl auf Polyglycol basierend

PAG Huiles synthétiques à base de polyglycol

(*) consultare il Servizio Tecnico Commerciale.

(*) consult Bonfiglioli Technical Service.

(*) Bitte wenden Sie sich an die technische Abteilung von Bonfiglioli.

(*) Consulter le service technique Bonfiglioli.

Quantità di lubrificante [l]

Oil quantity [l]

Schmiermittelmenge [l]

Quantité de lubrifiant [l]

(A5)

TA 30	TA 35	TA 40	TA 45	TA 50	TA 60	TA 70	TA 80	TA 100	TA 125
	1.2	2.1	3.1	8.0	7.5	11	17	20	27
0.50	TA 35_D	TA 40_D	TA 45_D	TA 50_D	TA 60_D	TA 70_D	TA 80_D	TA 100_D	TA 125_D
	1.1	1.8	3.6	7.3	10	14	11	18	27

Le quantità sono riferite alla posizione di montaggio A.

Quantities are only relevant to mounting position A.

Die Mengen beziehen sich an die Einbaulage A.

Les quantités sont référées au position montage A.



16 - POSIZIONI DI MONTAGGIO

16 - MOUNTING POSITIONS

16 - EINBAULAGEN

16 - POSITIONS DE MONTAGE

(A6)

	Legenda:	Key:	Zeichenerklärung:	Légende:
	Tappo di sfiato / carico	Filling / breather plug	Einfüll / Ablasschraube	Bouchon de event / remplissage
	Tappo di livello	Level plug	Östandsschraube	Bouchon de niveau
	Tappo di scarico	Drain plug	Öablasschraube	Bouchon de vidange

TA 30

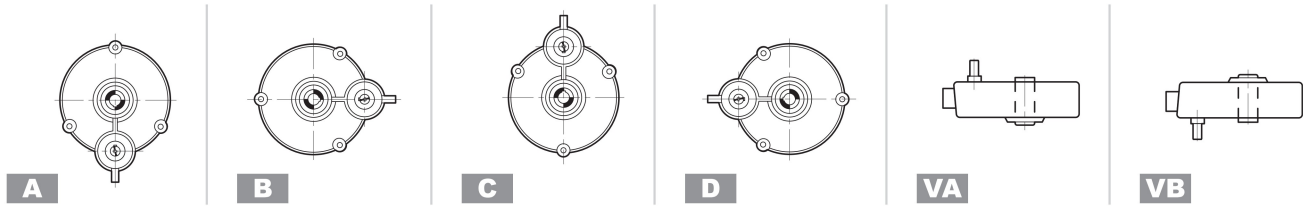

TA 35

TA 35 - 35_D

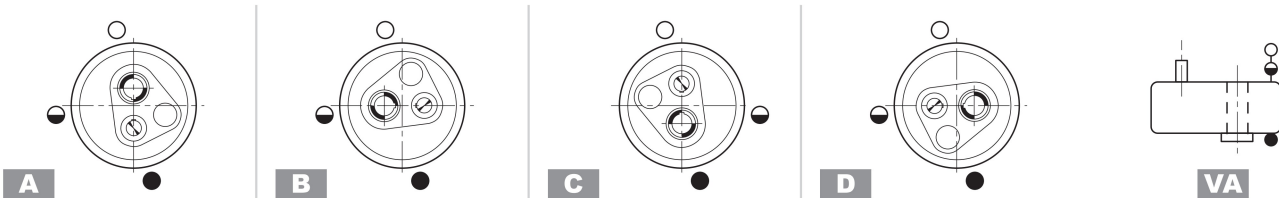

TA 35_D

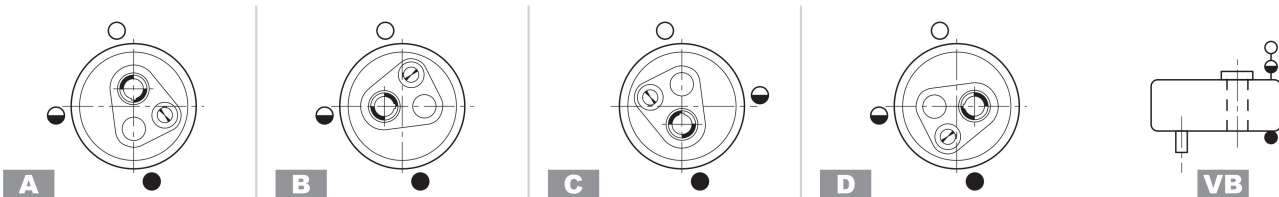

TA 40

TA 40 - 40_D

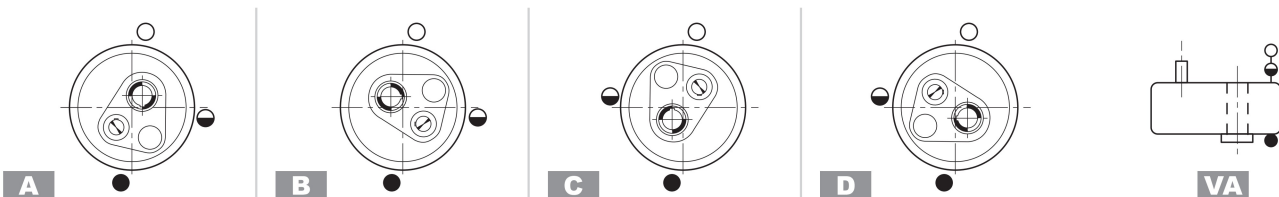

TA 40_D

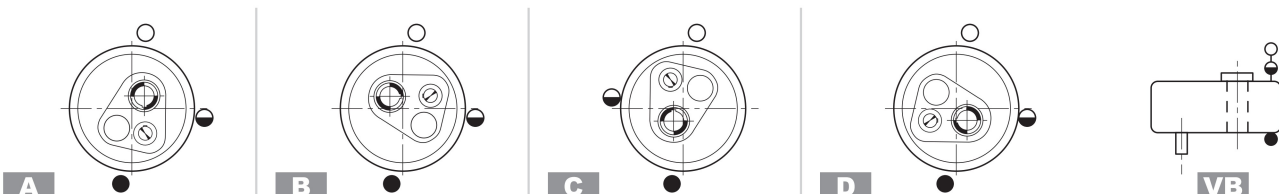



TA 45

TA 45 - 45_D

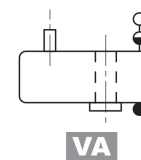
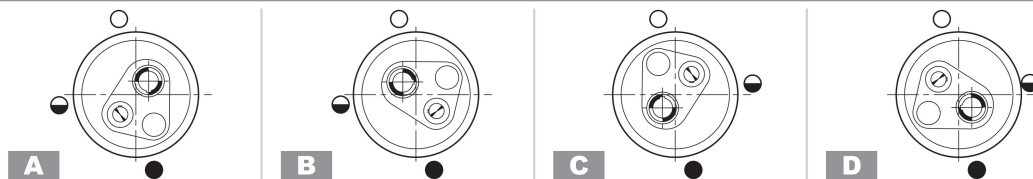

TA 45_D

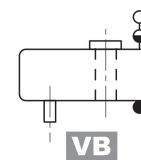
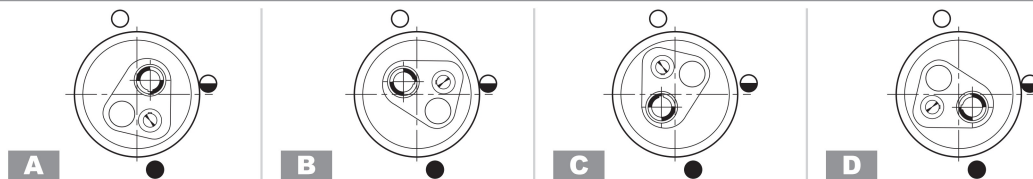

TA 50

TA 50 - 50_D

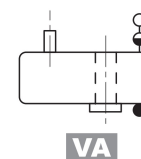
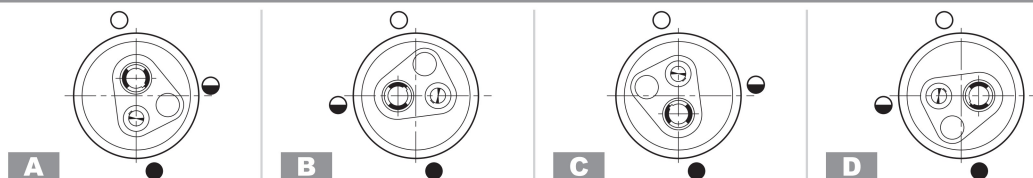

TA 50_D

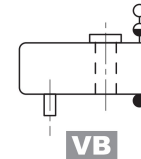
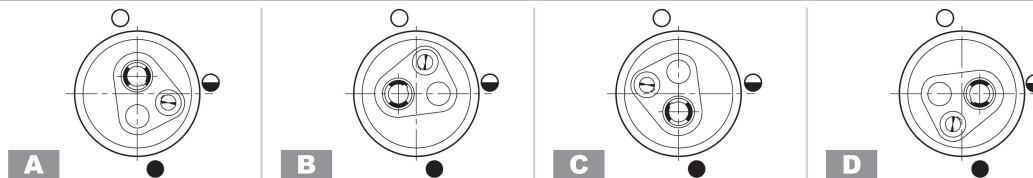

TA 60

TA 60 - 60_D

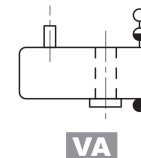
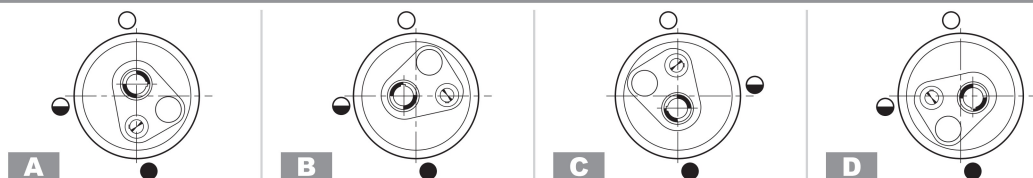

TA 60_D

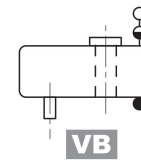
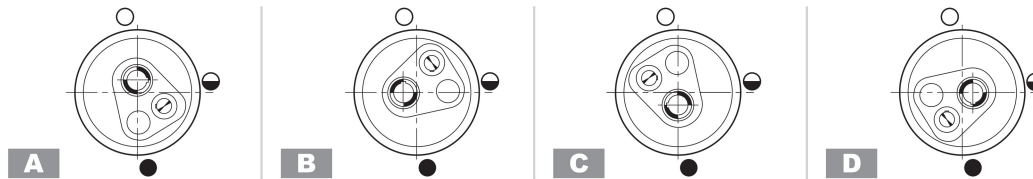

TA 70

TA 70 - 70_D

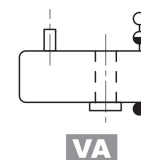
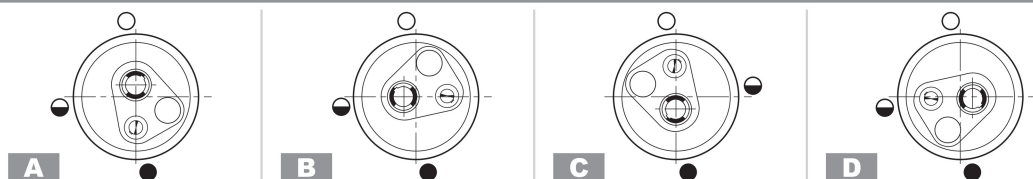

TA 70_D

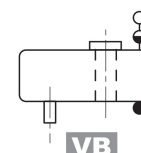
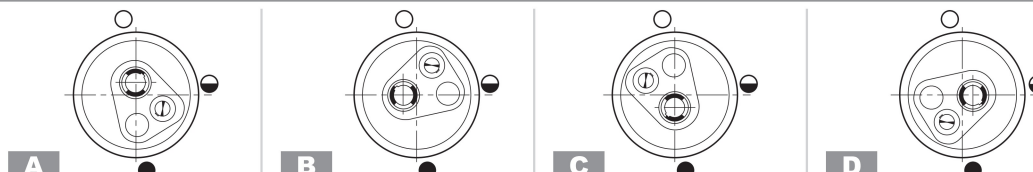



TA 80

TA 80 - 80_D

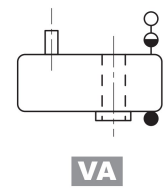
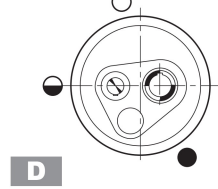
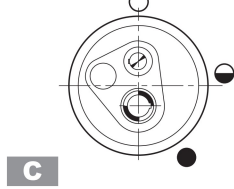
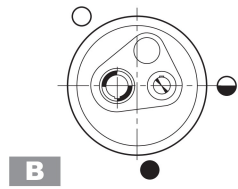
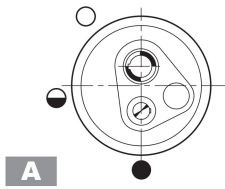

TA 80_D

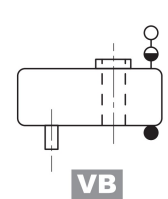
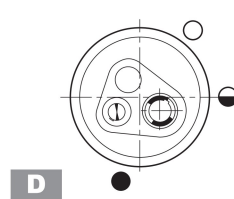
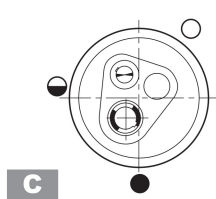
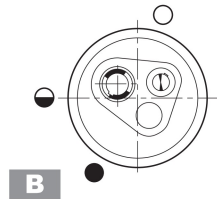
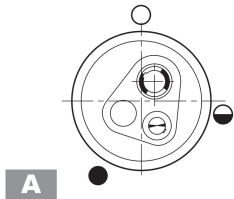

TA 100

TA 100 - 100_D

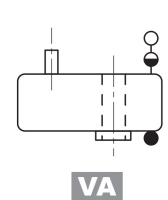
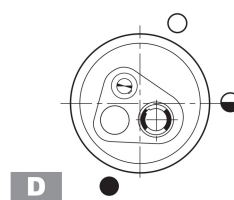
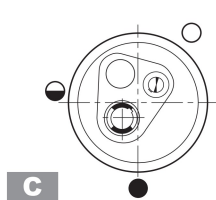
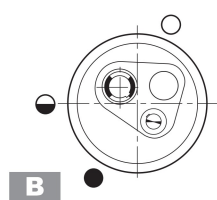
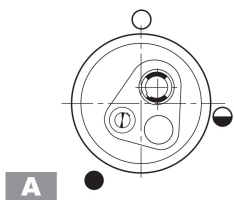

TA 100_D

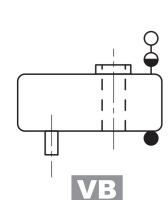
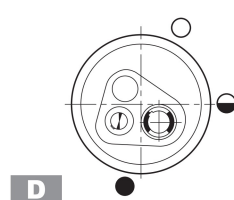
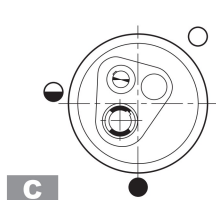
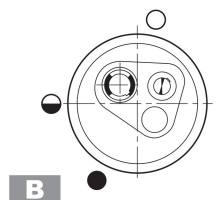
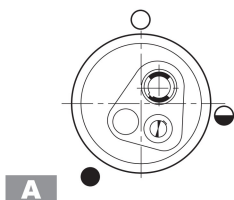

TA 125

TA 125 - 125_D

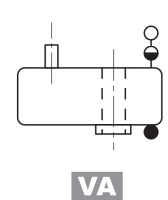
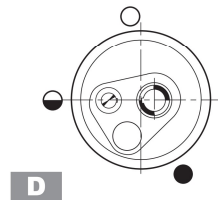
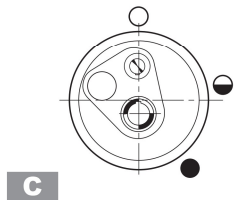
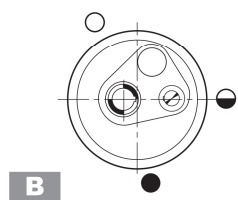
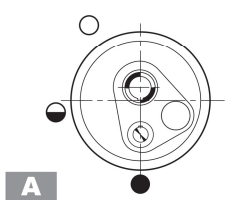

TA 125_D

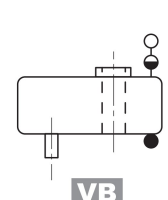
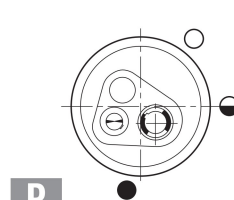
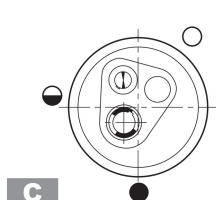
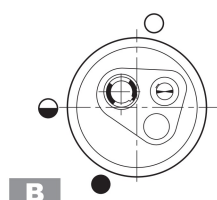
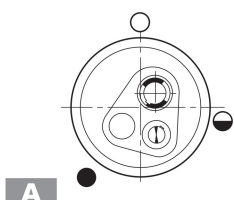



17 - CARICHI RADIALI

Organi di trasmissione calettati sugli alberi di ingresso e/o di uscita del riduttore generano forze la cui risultante agisce in senso radiale sull'albero stesso. L'entità di questi carichi deve essere compatibile con la capacità di sopportazione del sistema albero-cuscinetti del riduttore, in particolare il valore assoluto del carico applicato (R_{c1}) deve essere inferiore al valore nominale (R_{n1}) riportato nelle tabelle dati tecnici.

Il carico generato da una trasmissione esterna può essere calcolato, con buona approssimazione, tramite la formula seguente:

17 - OVERHUNG LOADS

External transmissions keyed onto input and/or output shaft generate loads that act radially onto same shaft.

Resulting shaft loading must be compatible with both the bearing and the shaft capacity. Namely shaft loading (R_{c1}), must be equal or lower than admissible overhung load capacity for shaft under study (R_{n1}). OHL capability listed in the rating chart section.

The load generated by an external transmission can be calculated with close approximation by the following equations:

17 - RADIALKRÄFTE

Die mit den Antriebs- und/oder Abtriebswellen des Getriebes verbundenen Antriebsorgane bilden Kräfte, die in radiale Richtung auf die Welle selbst wirken. Das Ausmaß dieser Kräfte muß mit der Festigkeit des Systems aus Getriebewelle/-lager kompatibel sein, insbesondere muß der absolute Wert der angetragenen Belastung (R_{c1}) unter dem in den Tabellen der Technischen Daten angegebenen Nennwert (R_{n1}) liegen.

Die von einem externen Antrieb erzeugte Kraft kann, recht genau, anhand der nachstehenden Formel berechnet werden:

17 - CHARGES RADIALES

Les organes de transmission calés sur les arbres d'entrée et/ou de sortie du réducteur génèrent des forces dont la résultante agit sur l'arbre dans le sens radial.

L'entité de ces charges doit être compatible avec la capacité d'endurance du système arbre-roulements du réducteur. Plus particulièrement, la valeur absolue de la charge appliquée (R_{c1}) doit être inférieure à la valeur nominale (R_{n1}) indiquée dans les tableaux des données techniques.

La charge générée par une transmission extérieure peut être calculée, avec une bonne approximation, au moyen de la formule suivante:

$$R_{c1}[\text{N}] = \frac{2000 \cdot M_1[\text{Nm}] \cdot K_r}{d[\text{mm}]} \quad (6)$$

M_1 [Nm]	Coppia applicata all'albero veloce	<i>Torque applied to input shaft</i>	Drehmoment auf die Antriebswelle	<i>Couple appliqué à l'arbre rapide</i>
d [mm]	Diametro primitivo dell'organo calettato sull'albero	<i>Pitch diameter of element keyed onto shaft</i>	Teilkreisdurchmesser von Bewegungselement, der auf der Abtriebswelle aufgeschraubt ist	<i>Diamètre primitif de l'organe monté sur l'arbre</i>
$K_r = 1$	Trasmissione con catena	<i>Chain transmission</i>	Kettenantrieb	<i>Transmission à chaîne</i>
$K_r = 1,25$	Trasmissione con ingranaggio	<i>Gear transmission</i>	Zahnradantrieb	<i>Transmission à engrenage</i>
$K_r = 1,5$	Trasmissione a cinghia trapezoidale	<i>V-belt transmission</i>	Antrieb über Keilriemen	<i>Transmission à courroie trapézoïdale</i>
$K_r = 2,0$	Trasmissione a cinghia piatta	<i>Flat belt transmission</i>	Antrieb über Flachriemen	<i>Transmission à courroie plate</i>

Il carico precedentemente calcolato si dovrà confrontare con il corrispondente valore nominale esposto a catalogo e dovrà verificarsi:

A comparison of shaft loading with catalogue OHL ratings should verify the following condition:



Der zuvor errechnete Wert muß mit dem im Katalog angegebenen Nennwert verglichen werden. Es muß sich folgendes ergeben:

La charge précédemment calculée doit être comparée avec la valeur nominale correspondante indiquée dans le catalogue, on doit vérifier :



$$R_{c1} \leq R_{n1} \quad (7)$$





TA 30 180 Nm

		i	$n_1 = 1400 \text{ min}^{-1}$				$n_1 = 900 \text{ min}^{-1}$				$n_1 = 500 \text{ min}^{-1}$				
			n_2 min^{-1}	Mn_2 Nm	Pn_1 kW	Rn_1 N	n_2 min^{-1}	Mn_2 Nm	Pn_1 kW	Rn_1 N	n_2 min^{-1}	Mn_2 Nm	Pn_1 kW	Rn_1 N	
TA 30	30	7.2	194	137	2.9	350	125	150	2.0	400	69	180	1.3	500	19
		10	140	137	2.1	350	90	150	1.4	400	50	180	1.0	500	
		12.7	110	137	1.6	350	71	150	1.1	400	39	180	0.8	500	



TA 35 420 Nm

		i	$n_1 = 1400 \text{ min}^{-1}$				$n_1 = 900 \text{ min}^{-1}$				$n_1 = 500 \text{ min}^{-1}$				
			n_2 min^{-1}	Mn_2 Nm	Pn_1 kW	Rn_1 N	n_2 min^{-1}	Mn_2 Nm	Pn_1 kW	Rn_1 N	n_2 min^{-1}	Mn_2 Nm	Pn_1 kW	Rn_1 N	
TA 35	35	5	280	200	6.0	700	180	250	4.8	800	100	350	3.8	1000	20
TA 35	35 D	10	140	300	4.6	500	90	350	3.5	600	50	400	2.2	750	
		15	93	350	3.6	500	60	400	2.6	600	33	400	1.5	750	
		19.5	72	380	3.0	500	46	400	2.0	600	25.6	400	1.1	750	
		25	56	400	2.5	500	36	400	1.6	600	20.0	420	0.92	750	

TA 40 950 Nm

		i	$n_1 = 1400 \text{ min}^{-1}$				$n_1 = 900 \text{ min}^{-1}$				$n_1 = 500 \text{ min}^{-1}$				
			n_2 min^{-1}	Mn_2 Nm	Pn_1 kW	Rn_1 N	n_2 min^{-1}	Mn_2 Nm	Pn_1 kW	Rn_1 N	n_2 min^{-1}	Mn_2 Nm	Pn_1 kW	Rn_1 N	
TA 40	40 45	5	280	480	14.4	1.000	180	550	10.6	1.200	100	700	7.5	1500	21
TA 40	40 45 D	10	140	600	9.2	850	90	750	7.4	950	50	800	4.4	1200	
		13.3	105	700	8.1	850	68	780	5.8	950	38	820	3.4	1200	
		15	93	750	7.7	850	60	800	5.3	950	33	850	3.1	1200	
		19.7	71	780	6.1	850	46	800	4.0	950	25.4	850	2.4	1200	
		25	56	800	4.9	850	36	850	3.4	950	20.0	900	2.0	1200	
		33.2	42	800	3.7	850	27.1	900	2.7	950	15.1	950	1.6	1200	



TA 45 1400 Nm

		i	$n_1 = 1400 \text{ min}^{-1}$				$n_1 = 900 \text{ min}^{-1}$				$n_1 = 500 \text{ min}^{-1}$				
			n_2 min^{-1}	Mn_2 Nm	Pn_1 kW	Rn_1 N	n_2 min^{-1}	Mn_2 Nm	Pn_1 kW	Rn_1 N	n_2 min^{-1}	Mn_2 Nm	Pn_1 kW	Rn_1 N	
TA 45	45 50 55	5	280	850	26	1500	180	950	18.4	1700	100	1100	11.8	2.150	22
TA 45	45 50 55 D	10	140	1000	15.4	1150	90	1200	11.9	1300	50	1300	7.2	1650	
		12.2	115	1100	13.9	1150	74	1200	9.7	1300	41	1300	5.9	1650	
		15	93	1200	12.3	1150	60	1250	8.3	1300	33	1300	4.8	1650	
		19.7	71	1250	9.8	1150	46	1300	6.5	1300	25.4	1350	3.8	1650	
		25	56	1300	8.0	1150	36	1350	5.4	1300	20.0	1400	3.1	1650	
30.4	46	1300	6.6	1150	29.6	1350	4.4	1300	16.4	1400	2.5	1650			





2300 Nm

TA 50

 	i	$n_1 = 1400 \text{ min}^{-1}$				$n_1 = 900 \text{ min}^{-1}$				$n_1 = 500 \text{ min}^{-1}$				
		n_2 min^{-1}	Mn_2 Nm	Pn_1 kW	Rn_1 N	n_2 min^{-1}	Mn_2 Nm	Pn_1 kW	Rn_1 N	n_2 min^{-1}	Mn_2 Nm	Pn_1 kW	Rn_1 N	
TA 50 50 55 60	5	280	1400	42	2250	180	1700	33	2500	100	1900	20	3100	23
TA 50 50 55 60 D	10	140	1750	27	1700	90	1900	18.8	1900	50	2000	11.0	2400	
	12	117	1800	23	1700	75	1900	15.7	1900	42	2000	9.2	2400	
	15	93	1900	19.5	1700	60	1950	12.9	1900	33	2100	7.7	2400	
	20.3	69	1950	14.8	1700	44	2000	9.8	1900	24.6	2100	5.7	2400	
	25	56	2000	12.3	1700	36	2100	8.3	1900	20.0	2300	5.1	2400	
	30	47	2000	10.3	1700	30	2100	6.9	1900	16.7	2300	4.2	2400	



3600 Nm

TA 60

 	i	$n_1 = 1400 \text{ min}^{-1}$				$n_1 = 900 \text{ min}^{-1}$				$n_1 = 500 \text{ min}^{-1}$				
		n_2 min^{-1}	Mn_2 Nm	Pn_1 kW	Rn_1 N	n_2 min^{-1}	Mn_2 Nm	Pn_1 kW	Rn_1 N	n_2 min^{-1}	Mn_2 Nm	Pn_1 kW	Rn_1 N	
TA 60 60 70	5	280	1900	57	3200	180	2100	41	3600	100	2900	32	4500	24
TA 60 60 70 D	10	140	3100	48	2600	90	3200	32	2900	50	3300	18.2	3600	
	12.2	115	3100	39	2600	74	3200	26	2900	41	3300	14.9	3600	
	15	93	3200	33	2600	60	3300	22	2900	33	3550	13.0	3600	
	20.3	69	3250	25	2600	44	3400	16.6	2900	24.6	3550	9.6	3600	
	25	56	3300	20	2600	36	3500	13.9	2900	20.0	3600	7.9	3600	
	30.4	46	3300	16.7	2600	29.6	3500	11.4	2900	16.4	3600	6.5	3600	

5100 Nm



TA 70

 	i	$n_1 = 1400 \text{ min}^{-1}$				$n_1 = 900 \text{ min}^{-1}$				$n_1 = 500 \text{ min}^{-1}$				
		n_2 min^{-1}	Mn_2 Nm	Pn_1 kW	Rn_1 N	n_2 min^{-1}	Mn_2 Nm	Pn_1 kW	Rn_1 N	n_2 min^{-1}	Mn_2 Nm	Pn_1 kW	Rn_1 N	
TA 70 70 85	5	280	2600	78	3700	180	3000	58	4200	100	4000	43	5200	25
TA 70 70 85 D	10	140	3800	59	3400	90	4400	44	3800	50	4500	25	4750	
	12.2	115	4000	51	3400	74	4400	36	3800	41	4500	20	4750	
	15	93	4400	45	3400	60	4500	30	3800	33	4900	18.0	4750	
	20.3	69	4500	34	3400	44	4600	22	3800	24.6	5000	13.6	4750	
	25	56	4600	28	3400	36	4900	19.4	3800	20.0	5100	11.2	4750	
	30.4	46	4600	23	3400	29.6	4900	16.0	3800	16.4	5100	9.2	4750	





TA 80

7000 Nm

 	i	$n_1 = 1400 \text{ min}^{-1}$				$n_1 = 900 \text{ min}^{-1}$				$n_1 = 500 \text{ min}^{-1}$				
		n_2 min^{-1}	Mn_2 Nm	Pn_1 kW	Rn_1 N	n_2 min^{-1}	Mn_2 Nm	Pn_1 kW	Rn_1 N	n_2 min^{-1}	Mn_2 Nm	Pn_1 kW	Rn_1 N	
TA 80 80 100	5	280	3700	111	4550	180	4200	81	5100	100	5000	54	6400	26
TA 80 80 100 D	10	140	5500	85	4200	90	6100	60	4700	50	6300	35	5900	
	12.5	112	5500	68	4200	72	6100	48	4700	40	6300	28	5900	
	15	93	6100	63	4200	60	6300	42	4700	33	6600	24	5900	
	20.3	69	6100	46	4200	44	6300	31	4700	24.6	6600	17.9	5900	
	25	56	6300	39	4200	36	6600	26	4700	20.0	7000	15.4	5900	
31.3	45	6300	31	4200	28.8	6600	21	4700	16.0	7000	12.3	5900		



TA 100

11000 Nm

 	i	$n_1 = 1400 \text{ min}^{-1}$				$n_1 = 900 \text{ min}^{-1}$				$n_1 = 500 \text{ min}^{-1}$				
		n_2 min^{-1}	Mn_2 Nm	Pn_1 kW	Rn_1 N	n_2 min^{-1}	Mn_2 Nm	Pn_1 kW	Rn_1 N	n_2 min^{-1}	Mn_2 Nm	Pn_1 kW	Rn_1 N	
TA 100 100 125	5	280	5500	165	5500	180	6200	120	6200	100	7000	75	7900	27
TA 100 100 125 D	10	140	9000	139	5000	90	9500	94	5600	50	10000	55	6800	
	12.3	114	9000	113	5000	73	9500	77	5600	41	10000	45	6800	
	15	93	9500	98	5000	60	10000	66	5600	33	10500	39	6800	
	20.3	69	9500	72	5000	44	10000	49	5600	24.6	10500	28	6800	
	25	56	9800	60	5000	36	10500	42	5600	20.0	11000	24	6800	
30.8	45	9800	49	5000	29.2	10500	34	5600	16.2	11000	19.7	6800		

TA 125

17000 Nm

 	i	$n_1 = 1400 \text{ min}^{-1}$				$n_1 = 900 \text{ min}^{-1}$				$n_1 = 500 \text{ min}^{-1}$				
		n_2 min^{-1}	Mn_2 Nm	Pn_1 kW	Rn_1 N	n_2 min^{-1}	Mn_2 Nm	Pn_1 kW	Rn_1 N	n_2 min^{-1}	Mn_2 Nm	Pn_1 kW	Rn_1 N	
TA 125 125 135	5	280	7500	226	6500	180	8000	155	7300	100	10000	107	9200	28
TA 125 125 135 D	10	140	12500	193	5500	90	14000	139	6200	50	15000	83	7700	
	12.3	114	12500	157	5500	73	14000	113	6200	41	15000	67	7700	
	15	93	12500	128	5500	60	15000	99	6200	33	16000	59	7700	
	20.3	69	14000	106	5500	44	15000	73	6200	24.6	16000	43	7700	
	25	56	15000	92	5500	36	16000	63	6200	20.0	17000	37	7700	
30.8	45	15000	75	5500	29.2	16000	51	6200	16.2	17000	30	7700		



19 - DIMENSIONI

19 - DIMENSIONS

19 - ABMESSUNGEN

19 - DIMENSIONS

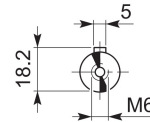
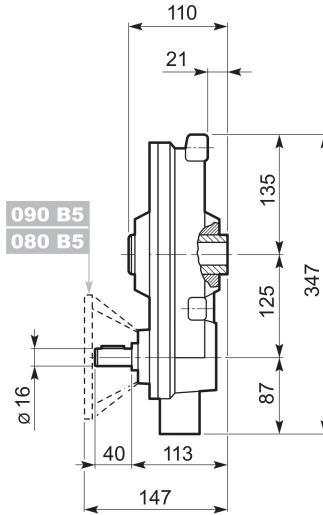
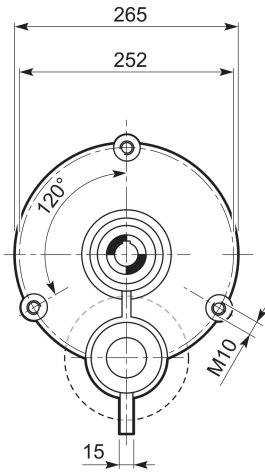

TA 30

	Kg
TA 30	17

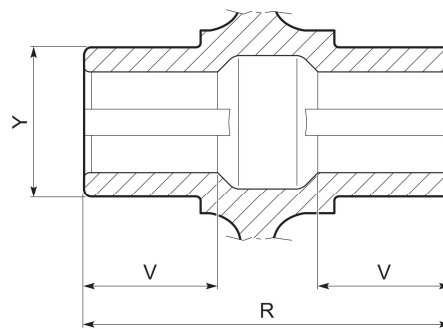
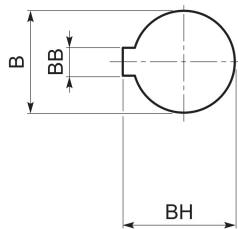

OUTPUT

	B H7	BB	BH	Y	R	V
TA 30	30	8	33.3	45	110	40



TA 35

TA 35

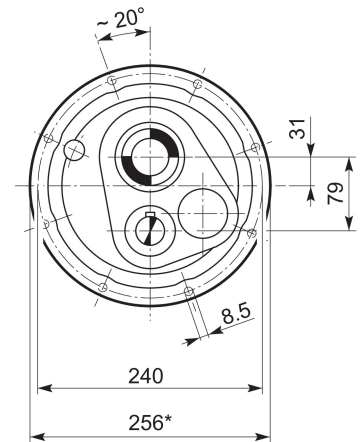
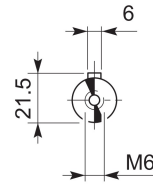
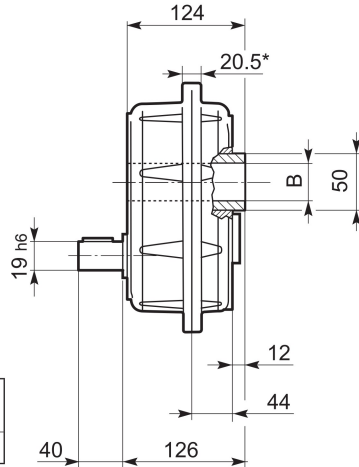

TA 35	16

TA 35_D

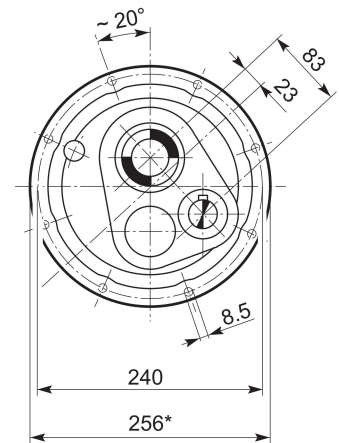
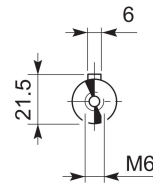
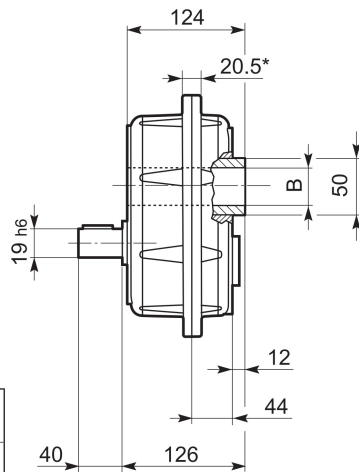

TA 35 D	18

OUTPUT

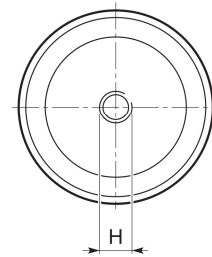
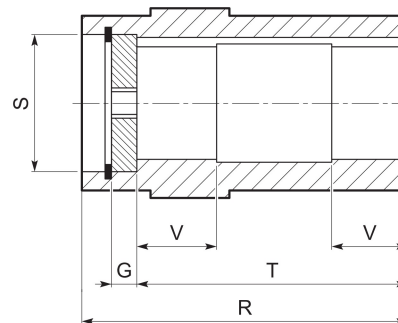
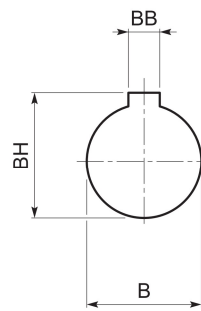

	B G7	BB	BH	G	H	R	S	T	V
TA 35	35	10	38.3	10	M10	124	42	106	30

* Le superfici sono grezze

* Surfaces are unmachined

* Oberflächen nicht bearbeitet

* Les surfaces sont non-usinées

TA 40

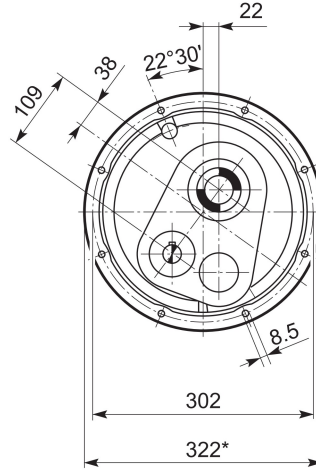
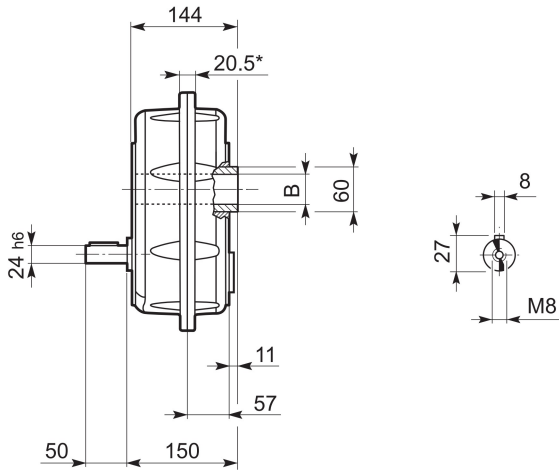

TA 40

TA 40	40	26
	45	26

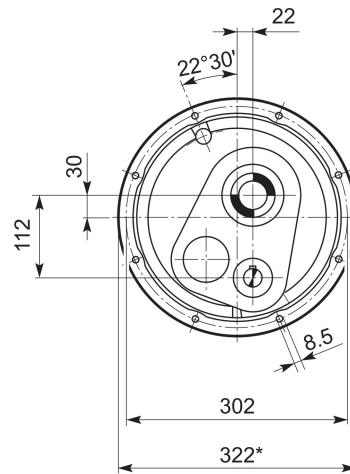
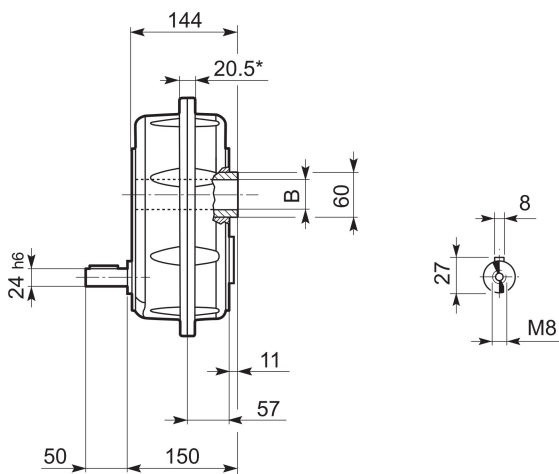

TA 40_D

TA 40	40	28
	45 D	28

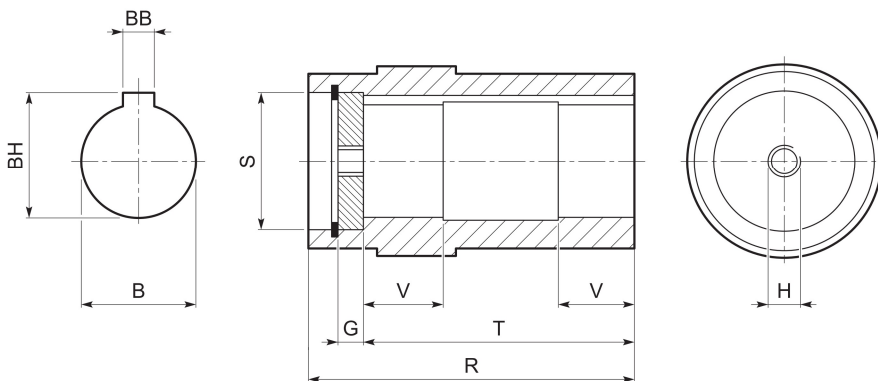

OUTPUT

		B G7	BB	BH	G	H	R	S	T	V
TA 40	40	40	12	43.3	12	M12	144	50	124	30
	45	45	14	47.3	12	M12	144	50	124	30

* Le superfici sono grezze

* Surfaces are unmachined



* Oberflächen nicht bearbeitet

* Les surfaces sont non-usinées





TA 45

TA 45

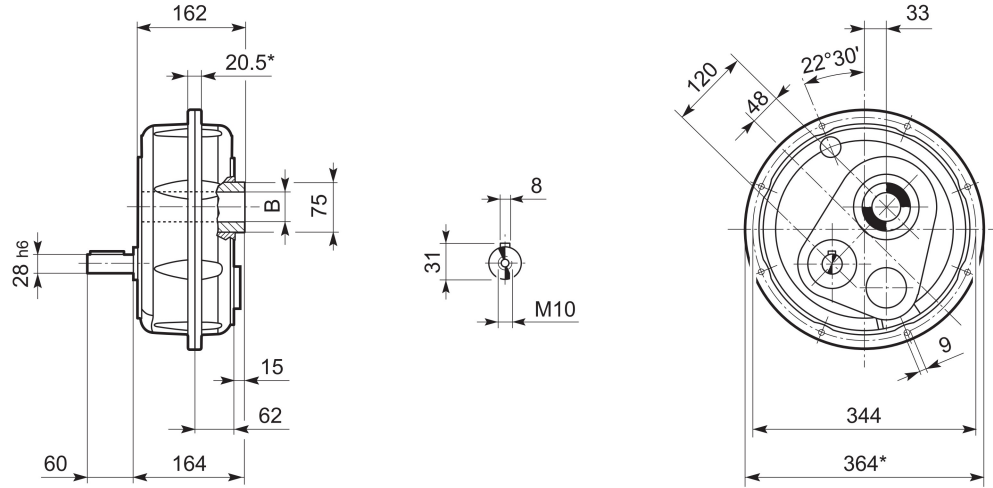
		 Kg
TA 45	45	34
	50	34
	55	33



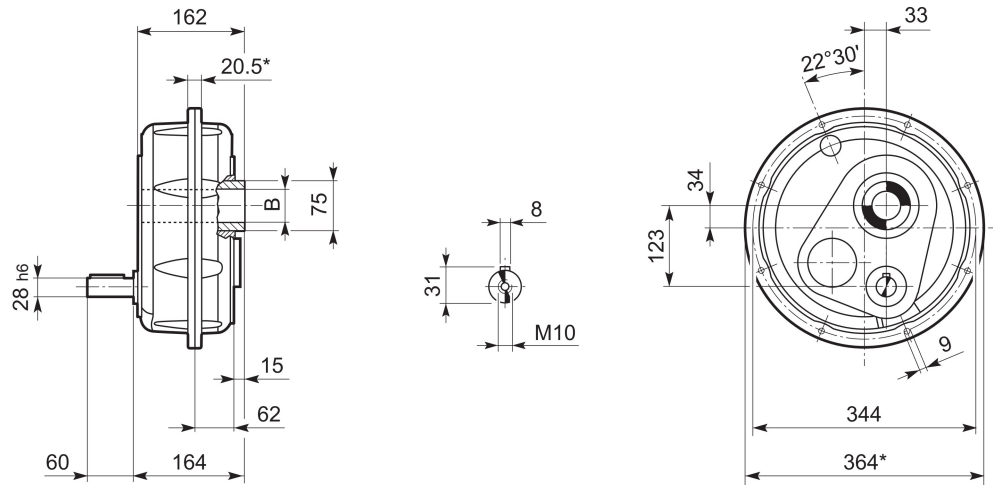

TA 45_D

		 Kg
TA 45	45	38
	50 D	38
	55	37

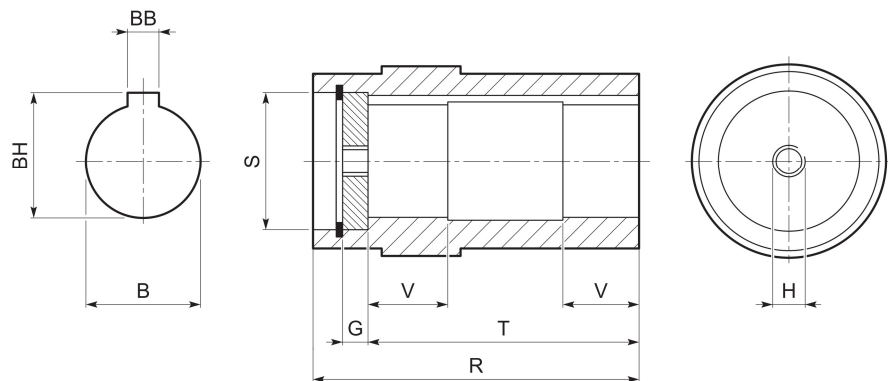

OUTPUT



		B G7	BB	BH	G	H	R	S	T	V
TA 45	45	45	14	48.8	14	M16	162	60	140	35
	50	50	14	53.8	14	M16	162	60	140	35
	55	55	16	59.8	14	M16	162	65	140	35

* Le superfici sono grezze

* Surfaces are unmachined

* Oberflächen nicht bearbeitet

* Les surfaces sont non-usinées

TA 50

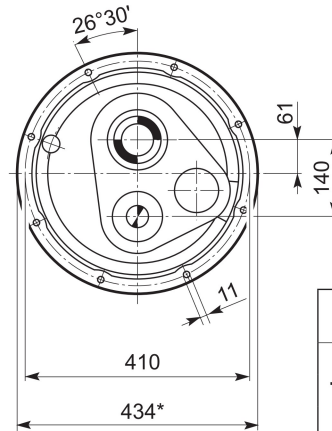
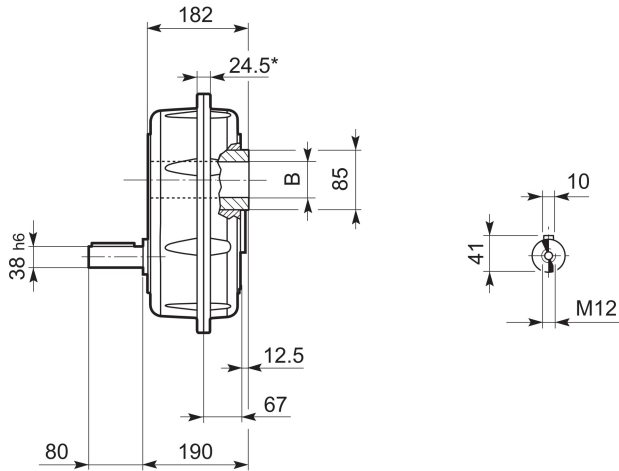

TA 50

TA 50	50	54
	55	54
	60	54

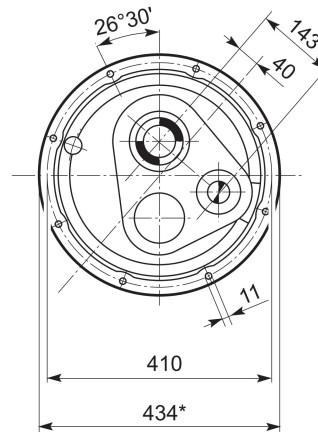
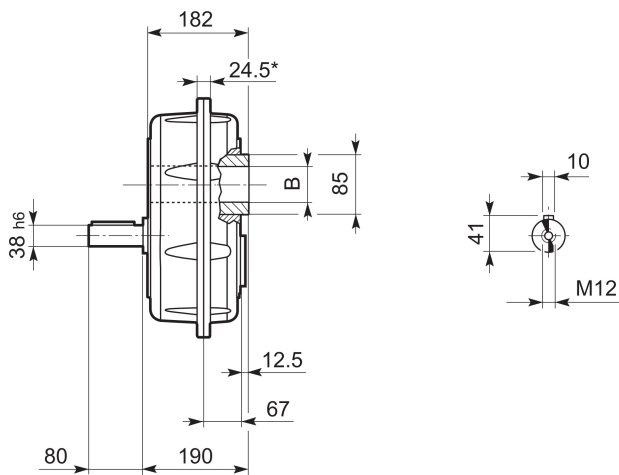

TA 50_D

TA 50	50	58
	55 D	58
	60	58

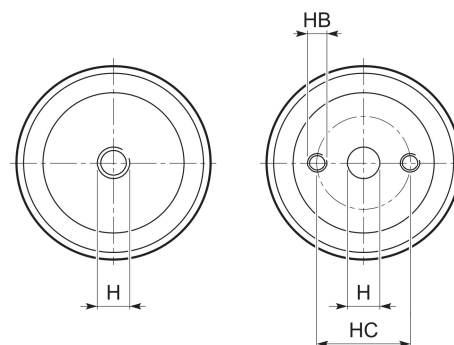
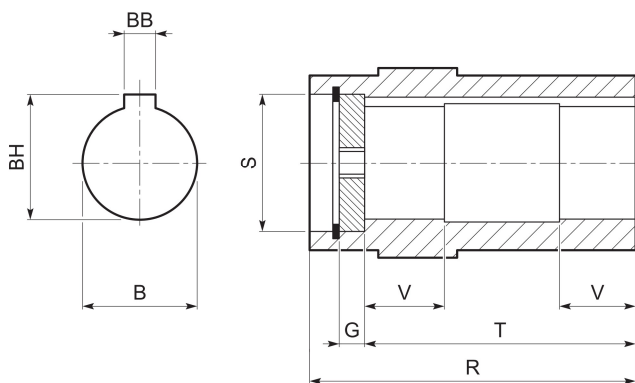

OUTPUT

		B G7	BB	BH	G	H	HB	HC	R	S	T	V
TA 50	50	50	14	53.8	14	M16	-	-	182	60	180	40
	55	55	16	59.3	14	M16	-	-	182	65	160	40
	60	60	18	64.4	14	17	M12	42	182	70	160	40

* Le superfici sono grezze

* Surfaces are unmachined

* Oberflächen nicht bearbeitet

* Les surfaces sont non-usinées



TA 60

TA 60

TA 60	60	83
	70	83

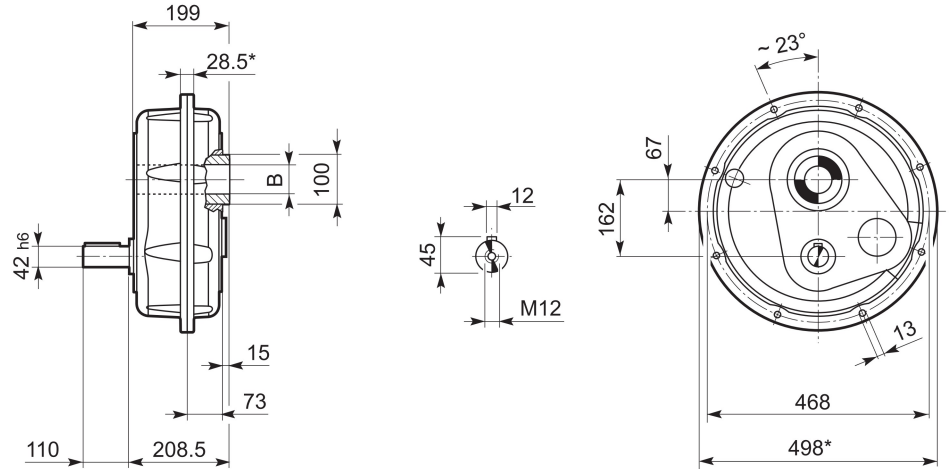

TA 60_D

TA 60	60 D	97
	70 D	97

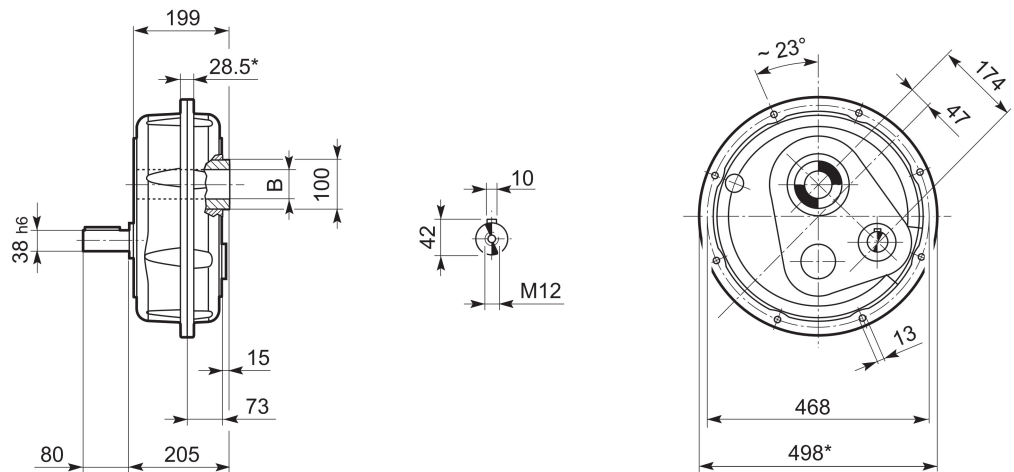

OUTPUT

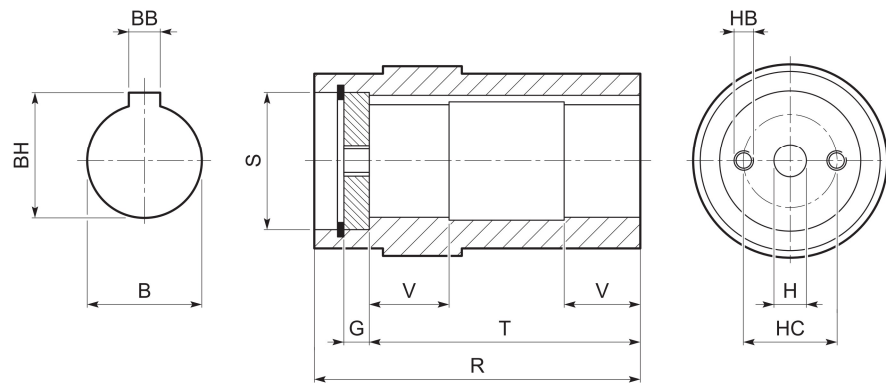

		B G7	BB	BH	G	H	HB	HC	R	S	T	V
TA 60	60	60	18	64.4	14	17	M12	42	199	70	175	45
	70	70	20	74.9	16	22	M16	50	199	85	175	45

* Le superfici sono grezze

* Surfaces are unmachined

* Oberflächen nicht bearbeitet

* Les surfaces sont non-usinées

TA 70

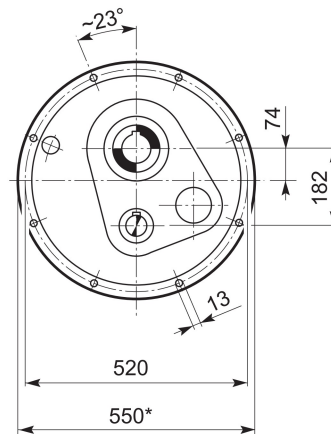
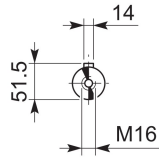
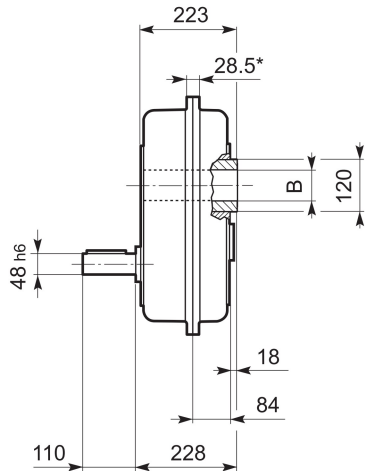

TA 70

TA 70	70	108
	85	106

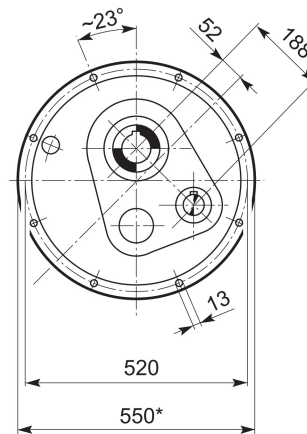
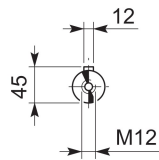
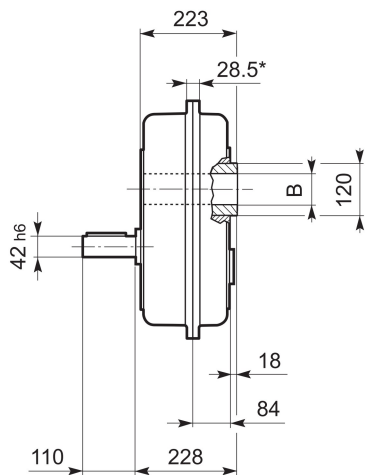

TA 70_D

TA 70	70 D	121
	85 D	120

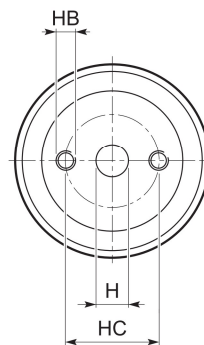
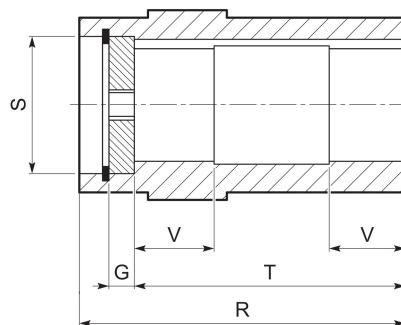
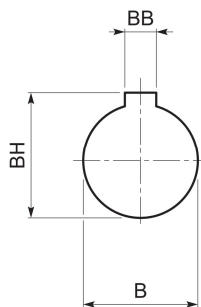

OUTPUT

		B G7	BB	BH	G	H	HB	HC	R	S	T	V
TA 70	70	70	20	74.9	16	22	M16	50	223	85	193	50
	85	85	22	90.4	18	22	M16	65	223	100	193	50

* Le superfici sono grezze

* Surfaces are unmachined



* Oberflächen nicht bearbeitet

* Les surfaces sont non-usinées





TA 80

TA 80

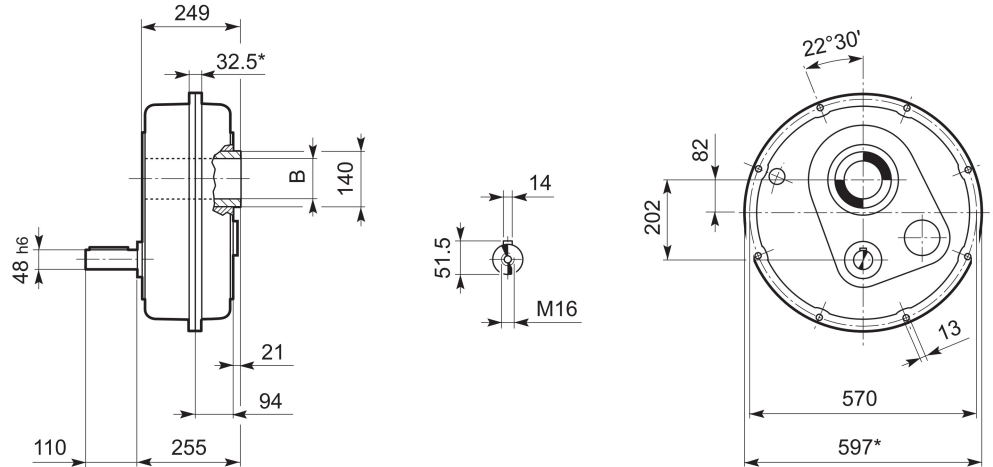
		
TA 80	80	145
	100	143



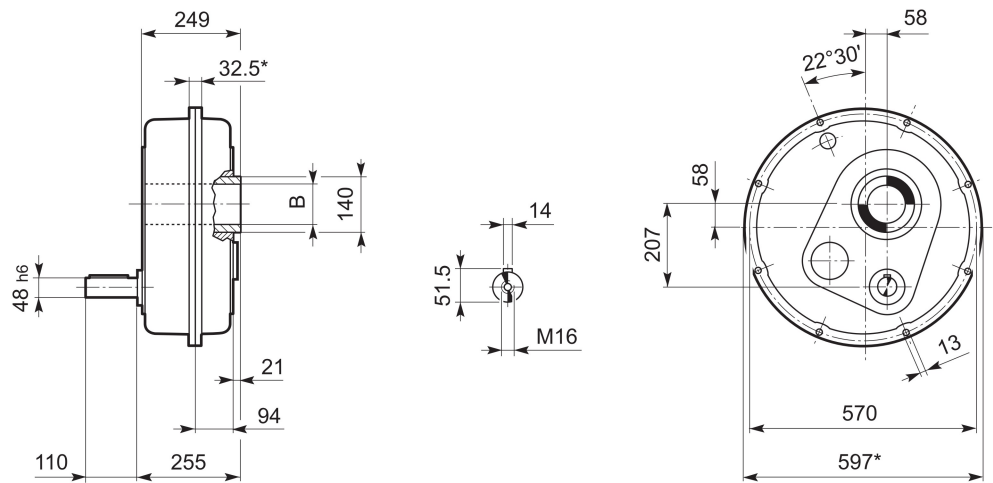

TA 80_D

		
TA 80	80	160
	100 D	158

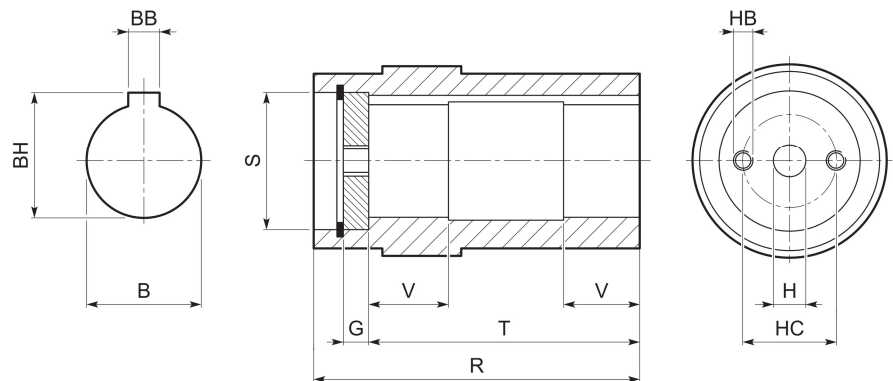

OUTPUT



		B G7	BB	BH	G	H	HB	HC	R	S	T	V
TA 80	80	80	22	85.4	18	22	M16	60	249	95	219	55
	100	100	28	106.4	20	26	M20	80	249	120	217	55

* Le superfici sono grezze

* Surfaces are unmachined

* Oberflächen nicht bearbeitet

* Les surfaces sont non-usinées

TA 100

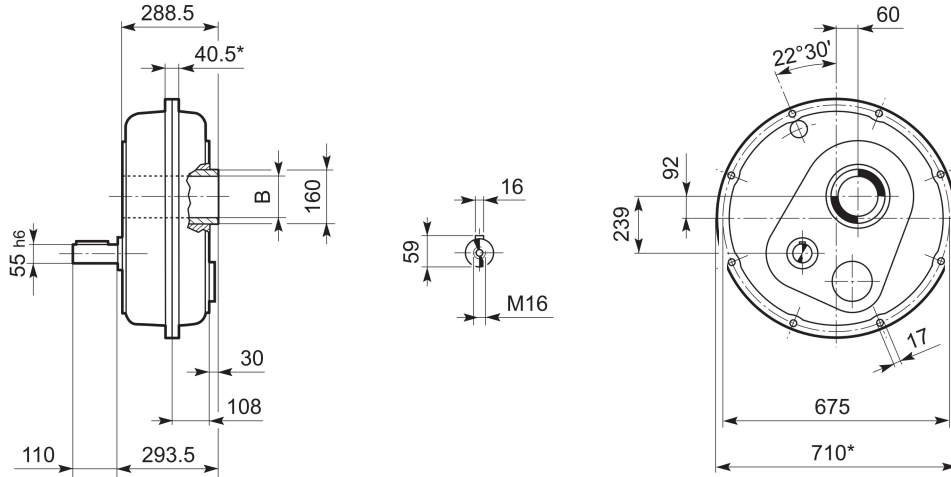

TA 100

TA 100	100	250
	125	248

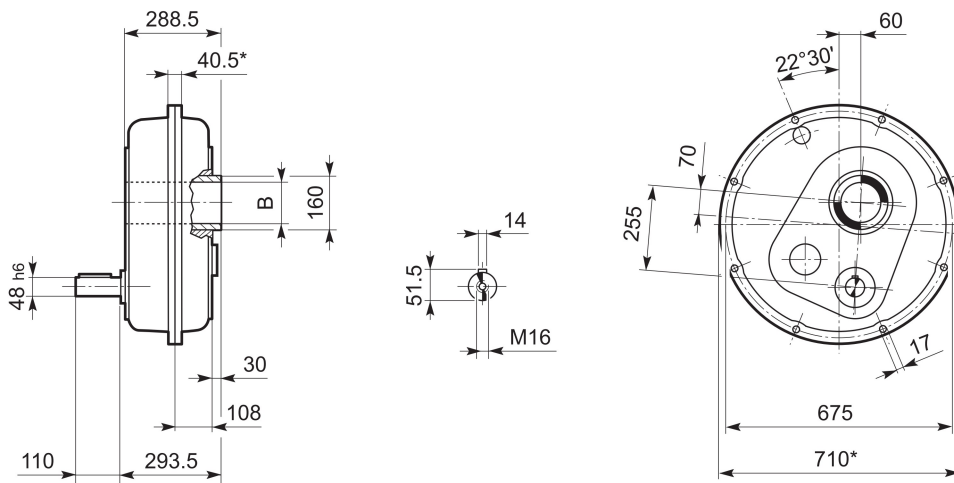

TA 100_D

TA 100	100	270
	125 D	267

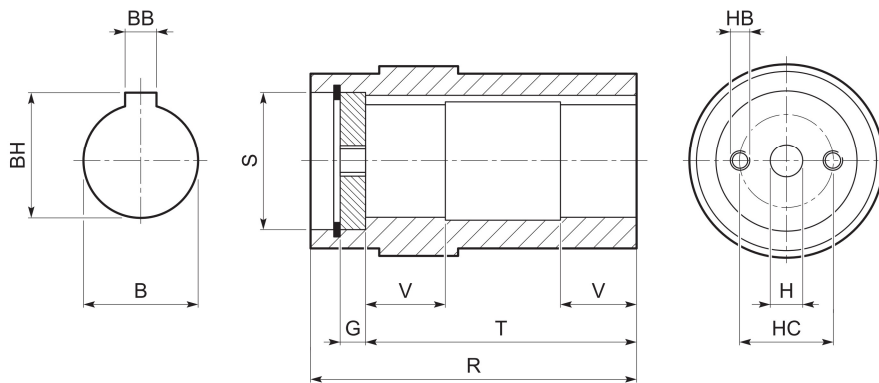

OUTPUT

		B G7	BB	BH	G	H	HB	HC	R	S	T	V
TA 100	100	100	28	106.4	20	26	M20	80	288.5	120	256.5	60
	125	125	32	132.3	20	26	M20	100	288.5	145	256.5	60

* Le superfici sono grezze

* Surfaces are unmachined

* Oberflächen nicht bearbeitet

* Les surfaces sont non-usinées



TA 125

TA 125

TA 125	125	330
	135	325

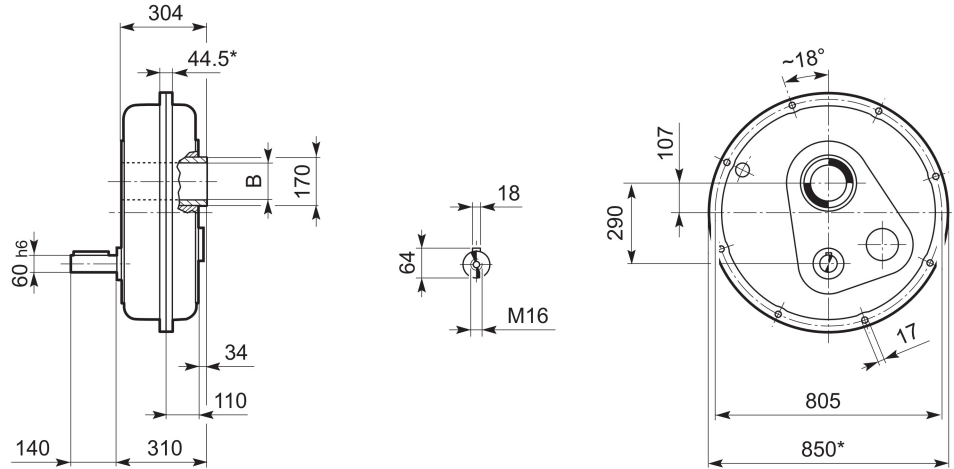

TA 125_D

TA 125	125	410
	135 D	415

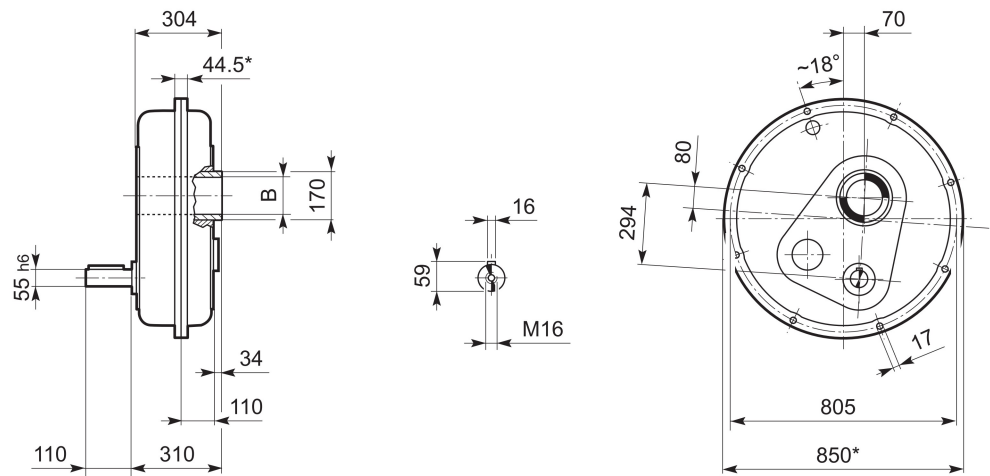

OUTPUT

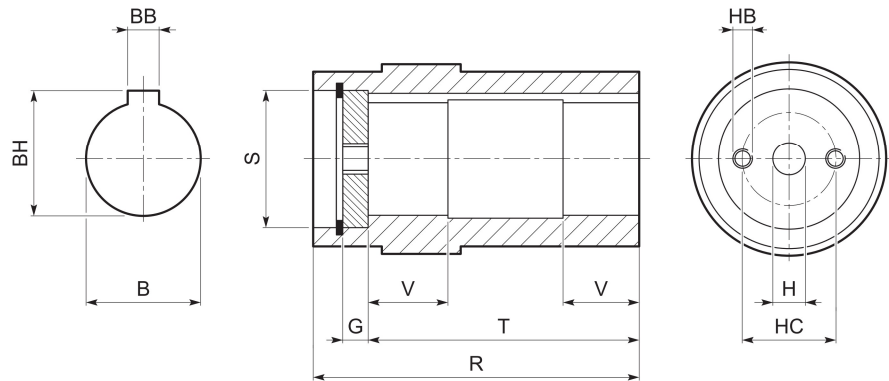

		B G7	BB	BH	G	H	HB	HC	R	S	T	V
TA 125	125	125	32	132.4	20	26	M20	100	304	145	267	65
	135	135	36	141.4	20	32	M24	100	304	150	267	65

* Le superfici sono grezze

* Surfaces are unmachined

* Oberflächen nicht bearbeitet

* Les surfaces sont non-usinées



TENDITORE / TENSION ARM / DREHMOMENTSTÜTZE / TENDEUR

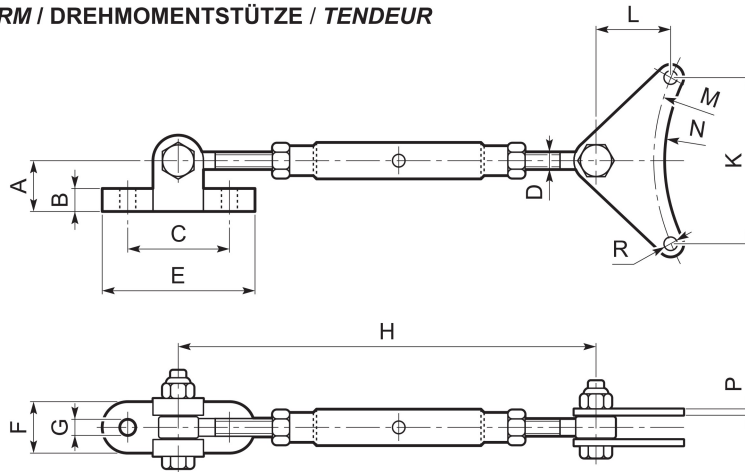

	⊕	A	B	C	D	E	F	G	H		K	L	M	N	R	P
									min	max						
TA 35	35	25	10	50	M10	75	25	8.5	200	300	92	45	120	111	8.5	4
TA 40	40 45	35	16	70	M12	105	35	10.5	210	310	115.5	51	151	143	8.5	4
TA 45	45 50 55	35	16	70	M12	105	35	10.5	210	310	132	57	172	164	10.5	5
TA 50	50 55 60	40	18	75	M14	115	40	12.5	240	360	157	70	205	195	10.5	5
TA 60	60 70	40	18	75	M14	115	40	12.5	240	360	179	84	234	221	12.5	5
TA 70	70 85	45	20	85	M16	135	50	14.5	260	410	199	100	260	247	12.5	6
TA 80	80 100	45	20	85	M16	135	50	14.5	260	410	218	102	285	272	13	6
TA 100	100 125	65	30	150	M20	220	70	25	340	560	258.5	115	337	324	17	10
TA 125	125 135	65	30	150	M20	220	70	25	340	560	306	135	402.5	382	17	10

FISSAGGIO CON TENDITORE / ARM ADJUSTEMENT / MONTAGE MIT DREHMOMENTSTÜTZE / FIXAGE AVEC TENDEUR

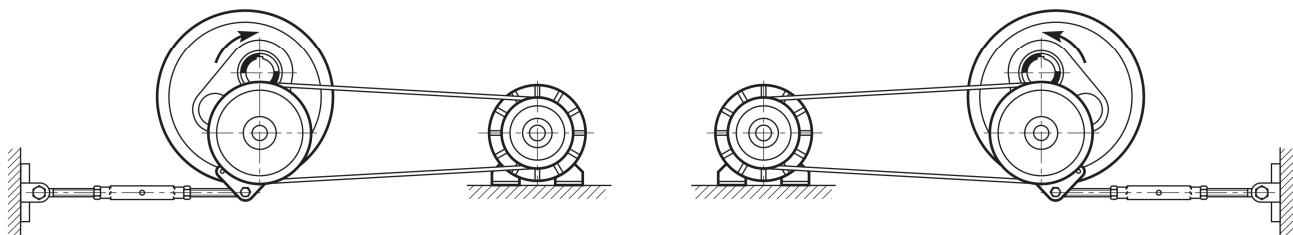

Affinché il fissaggio dei riduttori TA sia corretto, è necessario che il tenditore sia sollecitato a trazione.

In order to have a correct assembly of the gear boxes it is necessary that the tension arm is tensile stressed.

Damit die Befestigung von den TA Getrieben richtig ist, muss die Drehmomentstütze unter Druck sein.

Pour avoir un fixage correct du TA, il est nécessaire que le tendeur soit sollicité en traction.



R6				
	Descrizione	Description	Beschreibung	Description
19	Corretto disegni riduttore TA 30	<i>Drawings for gearbox TA 30 corrected</i>	Zeichnungen Getriebe für TA 30 korrigiert.	<i>Dessins pour reducteur TA 30 corrigées</i>